

x560-28YSQ

25 Gigabit Stackable Layer 3 Switch



Overview

Allied Telesis x560-28YSQ 25 Gigabit Layer 3 switch features high capacity, resiliency, and easy management. Flexible connectivity options make it the ideal choice for demanding data delivery applications. Enable 25G server connectivity for today's data-driven services, or high-performance in enterprise distribution environments.

24 x 1/10/25G ports and 4 x 40/100G uplinks provide deployment flexibility, while Virtual Chassis Stacking (VCStack™) enables a resilient solution where up to 4 units operate and are managed as a single virtual device.

Network automation

Vista Manager™ EX bundled with Allied Telesis Autonomous Management Framework™ Plus (AMF Plus) meets the increasing management requirements of modern networks. While AMF Plus allows an entire network to be securely and easily managed as a single virtual device, Vista Manager EX provides an intuitive and powerful graphical tool for monitoring and managing AMF Plus wired and Autonomous Wave Control (AWC) wireless devices.

Device and wireless management

The Device GUI enables graphical monitoring of key switch features to support easy management.

Integrated into the Device GUI, the wireless controller supports visibility and management of APs, making it ideal as a one-stop solution for small to medium-sized networks.

Resilient

The x560-28YSQ can form a VCStack of up to 4 units. In conjunction with link aggregation, VCStack provides an enhanced resiliency with no single point of failure to meet today's increasing demand for high-available networks with minimal downtime. Stacks can also be created over long distance fiber links, which is perfect for distributed environment.

Allied Telesis Ethernet Protection Switched Ring (EPSRing™), the standards-based G.8032 Ethernet Ring Protection, and Media Redundancy Protocol (MRP), ensure that distributed network segments have high-speed, resilient access to online resources and applications.

Reliable

The x560-28YSQ is designed with reliability in mind to guarantee continual delivery of essential services. Dual built in power supplies and near-hitless online stack reconfiguration enable maintenance to be performed without affecting network uptime.

Hyper-Converged Infrastructure (HCI)

The x560-28YSQ has the performance and resilience to support hyperconverged infrastructure, where servers, storage, and switches connect seamlessly for data-driven environments that are software controlled.

This lowers cost and complexity while enabling better scalability and agility in managing and deploying IT services.

Network orchestration

For easy integration into complex networks such as HCI that comprise physical, virtual, and multi-vendor devices, the x560-28YSQ features:

- NETCONF/RESTCONF + YANG data modelling for network automation.
- OpenFlow v1.3 for Software Defined Networking (SDN) orchestration.



Key Features

- 2.0 Terabit fabric
- SFP28 slots support 1/10/25G modules
- QSFP28 uplink slots support 40/100G modules
- Autonomous Management Framework Plus™ (AMF Plus)
- AMF Security compatible
- Active Fiber Monitoring for fiber data and stacking links
- VCStack up to 4 units locally or over distance
- EPSRing and G.8032 ERPS for resilient rings
- EPSR Master
- Data Center Bridging Capabilities Exchange Protocol (DCBX)
- Enhanced Transmission Selection (ETS)
- Priority-based Flow Control (PFC)
- Media Access Control Security (MACSec)
- Multicast Source Discovery Protocol (MSDP)
- Link Monitoring
- Bidirectional Forwarding Detection (BFD)
- Upstream Forwarding Only (UFO)
- VXLAN static tunnels
- NETCONF/RESTCONF with YANG data modelling
- OpenFlow v1.3 for SDN
- Integrated wireless controller

KEY FEATURES

Virtual Chassis Stacking (VCStack™)

Create a VCStack of up to four units at any port speed. Stacking links are connected in a ring so each device has dual connections to further improve resiliency. VCStack provides a highly available system where network resources are spread out across stacked units, reducing the impact if one of the units fails. Aggregating switch port on different units across the stack provides excellent network resiliency.

Long-Distance Stacking (VCStack LD)

Long Distance stacking allows a VCStack to be created over fiber links to span longer distances, perfect for a distributed network environment.

Integrated wireless controller

Optimize wireless network performance with the Autonomous Wave Control (AWC) wireless controller built-in to the Device GUI. AWC analyzes wireless traffic patterns and automatically reconfigures access points to meet demand, and ensure a superior Wi-Fi user experience.

Allied Telesis Autonomous Management Framework™ Plus (AMF Plus)

AMF Plus is a sophisticated suite of management tools that provide a simplified approach to network management. Common tasks are automated or made so simple that the everyday running of a network can be achieved without the need for highly-trained, and expensive, network engineers. Powerful features like centralized management, auto-backup, auto-upgrade, auto-provisioning and auto-recovery enable plug-and-play networking and zero-touch management.

The x560-28YSQ operating as the AMF Plus master stores firmware and configuration backups for all other network nodes. This enables auto-provisioning and auto-upgrade by providing appropriate files to new network members.

An AMF Plus license provides all standard AMF network management and automation features, and also enables the AMF Plus intent-based networking features in Vista Manager EX.

AMF Security and Application Proxy

The AMF-Security (AMF-Sec) solution enables internal LAN threat detection and automatic end-point isolation to protect the network. The AMF Application Proxy (available with a feature license) enables the AMF-Sec controller to communicate with the AMF Plus master when a threat is detected, so the AMF Plus master can take action to block the threat at source by quarantining the infected end-point.

Flexible Port Speeds

24 x SFP28 slots support any combination of 1G, 10G, and 25G modules, while the 4 x QSFP28 uplink slots support 40G or 100G modules. This flexibility enables easy connectivity to a variety of systems, and simple performance upgrades.

Quality of Service

Data Center Bridging Capabilities Exchange Protocol (DCBX) lets network devices in the data center automatically discover and negotiate settings for DCB features, ensuring optimized performance

Enhanced Transmission Selection (ETS) provides quality of service by allocating bandwidth to important traffic classes, with the flexibility to share remaining bandwidth to maximize traffic throughput and performance.

Priority-based Flow Control (PFC) enables lossless data forwarding by managing high priority traffic queues to support their class-of-service.

Virtual Routing and Forwarding (VRF-Lite)

VRF-Lite provides Layer 3 network virtualization by dividing a single switch into multiple independent virtual routing domains. With independent routing domains, IP addresses can overlap without causing conflict, allowing multiple customers to have their own secure virtual network within the same physical infrastructure. VRF-Lite supports IPv4 and IPv6 unicast and multicast traffic.

The built-in DHCP Server on the x560-28YSQ is VRF aware, enabling the supply of IP addresses to clients across multiple isolated networks.

Ethernet Protection Switched Ring (EPSRing™)

EPSRing allows several switches to form protected rings with 50ms failover—perfect for high performance at the core of Enterprise or Provider Access networks. The AT-x560-28YSQ can act as the EPSR Master.

SuperLoop Protection enables a link between two EPSR nodes to be in separate EPSR domains, improving redundancy and network fault resiliency.

G.8032 Ethernet Ring Protection

G.8032 provides standards-based high-speed ring protection, that also interoperate with Allied Telesis EPSR.

Ethernet Connectivity Fault Monitoring (CFM) proactively monitors links and VLANs, and provides alerts when a fault is detected.

sFlow

sFlow is an industry-standard technology for monitoring high-speed switched networks. It provides complete visibility into network use, enabling performance optimization, usage accounting/billing, and defense against security threats. Sampled packets sent to a collector (up to 5 collectors can be configured) ensure it always has a real-time view of network traffic

Active Fiber Monitoring (AFM)

AFM prevents eavesdropping on fiber communications by monitoring received optical power. If an intrusion is detected, the link can be automatically shut down, or an operator alert can be sent.

Media Access Control Security (MACSec)

802.1AE MACSec secures all traffic on point-to-point Ethernet links between directly connected nodes, ensuring protection against security threats such as denial of service, intrusion, man-in-the-middle, passive wiretapping, and playback attacks.

TACACS+ Command Authorization

TACACS+ Command Authorization offers centralized control over which commands may be issued by each specific AlliedWare Plus device user. It complements authentication and accounting services for a complete AAA solution.

VLAN Translation

Service Providers can use VLAN Translation to provide customer traffic with a unique VLAN-ID for use within the SP's network. It does this by mapping traffic arriving on a VLAN to a different VLAN on the outgoing paired interface.

This feature is also useful in Enterprise environments where it can be used to merge two networks together, without manually reconfiguring the VLAN numbering scheme.

Bidirection Forwarding Detection (BFD)

BFD enables fast detection of link failures, so recovery time is minimized. BFD works with static routes, and also alongside BGP and OSPF dynamic routing protocols supporting faster shutdown of neighbor connections if a peer session goes down. When using VRF-Lite, BFD is supported globally or within a domain.

Upstream Forwarding Only (UFO)

UFO lets you manage which ports in a VLAN can communicate with each other, and which only have upstream access to services, for secure multi-user deployment.

Multicast Source Discovery Protocol (MSDP)

MSDP enables two or more PIM-SM (Sparse Mode) domains to share information on active multicast sources, for more efficient forwarding of multicast traffic.

Link Monitoring (Linkmon)

Linkmon enables network health monitoring by regularly sending probes over key links to gather metrics comprising latency, jitter, and probe loss.

This supports pro-active network management and can also be used with triggers to automate a change to device or network configuration in response to the declining health of a monitored link.

Virtual Extensible LAN (VXLAN) tunnels

VXLAN tunnels let you join two or more L2 networks over an L3 IP network to form a single L2 broadcast domain. VXLAN adds scalability to cloud computing environments. The x560-28YSQ supports static VXLAN tunnels.

NETCONF/RESTCONF

NETCONF/RESTCONF with YANG data modeling provides a standardized way to represent data and securely configure devices, supporting existing management systems.

Software Defined Networking (SDN)

OpenFlow is a key technology for SDN orchestration. SDN controllers and other tools support automated behavior in a network and allow customized applications and services to be run.

KEY SOLUTIONS

Flexible distribution

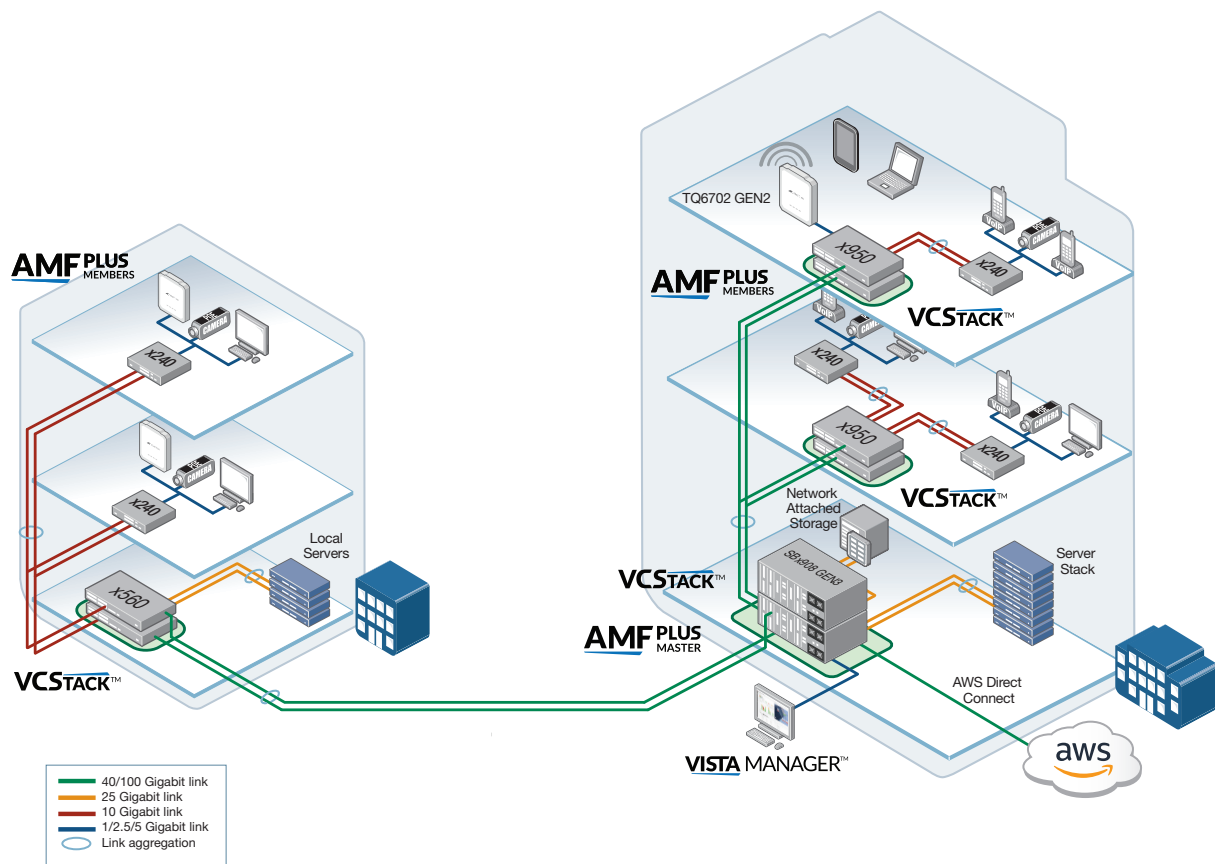

Today's enterprises demand ready access to online resources and applications and require a high-performing network that can seamlessly carry multiple converged services. This campus solution uses the x560-28YSQ for flexible distribution partnered with a SwitchBlade x908 GEN3 network core, providing high availability and capacity, along with ease of management.

Using VCStack at the core and distribution layers of the network allows multiple switches to appear as a single virtual chassis, simplifying management. In normal operation, the full bandwidth of

the network is used, ensuring always-available online services.

Using Amazon Web Services (AWS) Direct Connect ensures immediate access to cloud-based services, alongside locally stored business data and applications, to fully support modern hybrid-cloud environments.

The flexibility of the x560-28YSQ to connect at 10G and 25G speeds supports high-speed edge switches and server access, while 40G and 100G uplinks provide immediate data transfer to the network core. Dual power supplies in

the x560 distribution switches maximize network uptime and ensure connectivity to business-critical information.

AMF Plus allows the network to be unified for ease of management, with the Master device automatically backing up the entire network, and enabling plug-and-play networking with zero touch expansion and recovery. Vista Manager enables visual management and monitoring of the entire network including all wired, wireless, and endpoint devices.

SPECIFICATIONS

	1/10/25G SFP28 ports	40/100G QSFP28 ports	Switching Fabric	Forwarding Rate
x560-28YSQ	24	4	2.0Tbps	800Mpps

Physical Specifications

	Width	Depth	Height	Mounting	Weight
x560-28YSQ	441 mm (17.36 in)	421 mm (16.57 in)	44 mm (1.73 in)	Rack-mount 1 RU	5.95 kg (13.11 lb)

Power and Noise Characteristics

	Max Power Consumption	Max Heat Dissipation	Noise
x560-28YSQ	300W	1024 BTU/h	50-60 db

Latency (microseconds)

	Port Speed				
	1Gbps	10Gbps	25Gbps	40Gbps	100Gbps
x560-28YSQ	4.55µs	2.66µs	2.24µs	2.04µs	1.59µs

Performance

- Up to 64K MAC addresses
- Up to 1,000 static routes
- Up to 12,000 dynamic routes
- 2GB DDR SDRAM
- 4096 configurable VLANs
- 256 MB flash memory
- Packet Buffer memory: 8MB
- Supports up to 10KB L2 jumbo frames

Reliability

- Modular AlliedWare™ operating system
- Dual built-in power supplies
- Full environmental monitoring of PSU internal temperature and internal voltages. SNMP traps alert network managers in case of any failure

Diagnostic Tools

- Active Fiber Monitoring detects tampering on optical links
- Cable fault locator (TDR)
- Find-me device locator
- Connectivity Fault Management (CFM) for use with G.8032 ERPS
- Link Monitoring
- Automatic link flap detection and port shutdown
- Optical Digital Diagnostic Monitoring (DDM)
- Ping polling for IPv4 and IPv6
- Port mirroring
 - No limit on mirrored ports
 - Up to 7 mirror (analyzer) ports
- VLAN mirroring (RSPAN)
- TraceRoute for IPv4 and IPv6
- Uni-Directional Link Detection (UDLD)

IPv4 Features

- Black hole routing
- DHCP client, relay and server for IPv4 and IPv6
- Directed broadcast forwarding
- DNS relay
- Equal Cost Multi Path (ECMP) routing
- Policy-based routing
- Route maps
- Route redistribution (OSPF, BGP, RIP)
- Static IPv4 multicast routing
- Static unicast routing for IPv4
- UDP broadcast helper (IP helper)
- Virtual Routing and Forwarding Lite (VRF-Lite) up to 64 domains

IPv6 Features

- DHCPv6 client and relay
- DNSv6 client, DNSv6 relay
- IPv4 and IPv6 dual stack
- IPv6 aware storm protection and QoS
- IPv6 hardware ACLs
- Device management over IPv6 networks with SNMPv6, Telnetv6 and SSHv6
- IPv6 QoS support
- NTP client and server
- Static and dynamic IPv6 multicast routing
- Static and dynamic unicast routing for IPv6
- Log to IPv6 hosts with Syslog v6
- VRF-Lite

Management

- Autonomous Management Framework Plus (AMF plus) enables powerful centralized management and zero-touch device installation and recovery
- Try AMF Plus for free with the built-in Starter license (includes network management and

automation features, but not Vista Manager AMF Plus menu features)

- NETCONF/RESTCONF northbound interface with YANG data modelling
- OpenFlow northbound interface
- Console management port on the front panel for ease of access
- Eco-friendly mode allows ports and LEDs to be disabled to save power
- Industry-standard CLI with context-sensitive help
- Powerful CLI scripting engine
- Comprehensive SNMP MIB support for standards-based device management
- Built-in text editor
- Event-based triggers allow user-defined scripts to be executed upon selected system events
- USB interface allows software release files, configurations and other files to be stored for backup and distribution to other devices
- Integrated wireless AP controller
- Web-based Graphical User Interface (GUI)

Quality of Service (QoS)

- 8 priority queues with a hierarchy of high priority queues for real time traffic, and mixed scheduling, for each switch port
- Limit bandwidth per port or per traffic class down to 64kbps
- Wirespeed traffic classification with low latency essential for VoIP and real-time streaming media applications
- Policy-based QoS based on VLAN, port, MAC and general packet classifiers
- Policy-based storm protection
- Extensive remarking capabilities
- Taildrop for queue congestion control
- Queue scheduling options for strict priority, weighted round robin or mixed scheduling
- IP precedence and DiffServ marking based on layer 2, 3 and 4 headers
- Data Center Bridging Capabilities Exchange Protocol (DCBX)
- Enhanced Transmission Selection (ETS)
- Priority-based Flow Control (PFC)

Resiliency Features

- Control Plane Prioritization (CPP) ensures the CPU always has sufficient bandwidth to process network control traffic
- Dynamic link failover (host attach)
- EPSR (Ethernet Protection Switched Rings)
- EPSRing SuperLoop Protection (SLP)
- Ethernet Ring Protection Switching (ITU-T G.8032 ERPS)
- Link aggregation (LACP) on LAN ports
- Loop protection: loop detection and thrash limiting
- PVST+ compatibility mode
- Spanning Tree Protocols (STP, RSTP, MSTP)
- STP root guard
- VCStack fast failover minimizes network disruption
- Flexi-stacking - use any port-speed to stack
- Long-distance stacking (LD-VCStack)
- Virtual Router Redundancy Protocol (VRRP)

Security Features

- Access Control Lists (ACLs) based on layer 3 and 4 headers
- Configurable ACLs for management traffic
- Dynamic ACLs assigned via port authentication
- ACL Groups enable multiple hosts/ports to be included in a single ACL, reducing configuration
- Auth fail and guest VLANs
- RADIUS and TACACS+ Authentication, Authorisation and Accounting (AAA)
- Bootloader can be password protected for device security
- BPDU protection
- DHCP snooping, IP source guard and Dynamic ARP Inspection (DAI)
- DoS attack blocking and virus throttling
- Dynamic VLAN assignment
- Local RADIUS server for user and device authentication
- MAC-based authentication
- MAC address filtering and MAC address lock-down
- Media Access Control Security (MACSec)
- Network Access and Control (NAC) features manage endpoint security
- Port-based learn limits (intrusion detection)
- RADIUS group selection per VLAN or port
- RADIUS proxy
- Secure Copy (SCP)
- Secure File Transfer Protocol (SFTP) client
- Simple Certificate Enrollment Protocol (SCEP) supports secure management
- Strong password security and encryption
- Tri-authentication: MAC-based, web-based and IEEE 802.1x

VLAN Support

- Private VLANs provide security and port isolation for multiple customers using the same VLAN
- Upstream Forwarding Only (UFO)
- VLAN ID translation
- Voice VLAN

Environmental Specifications

- Operating temperature range:
0°C to 50°C (32°F to 122°F)
Derated by 1°C per 305 meters (1,000 ft)
- Storage temperature range:
-25°C to 70°C (-13°F to 158°F)
- Operating relative humidity range:
5% to 90% non-condensing
- Storage relative humidity range:
5% to 95% non-condensing
- Operating altitude:
3,000 meters maximum (9,843 ft)

Electrical approvals and compliances

- EMC: ETSI EN300-386, EN300-132-2,
- FCC class A, VCCI class A
- Immunity: EN55024, EN61000-3-levels 2 (Harmonics), and 3 (Flicker) – AC models only

Safety

- Standards: UL62368-1, CAN/CSA-C22.2 No. 60950-1-03, EN60950-1, EN60825-1, AS/NZS 60950.1
- Certifications: UL, cUL, UL-EU

Restrictions on Hazardous Substances (RoHS) Compliance

- EU RoHS compliant
- China RoHS compliant-1

STANDARDS & PROTOCOLS

AlliedWare Plus Operating System

Version 5.5.6

Authentication

- RFC 1321 MD5 Message-Digest algorithm
- RFC 1828 IP authentication using keyed MD5

Border Gateway Protocol (BGP)

- BGP dynamic capability
- BGP outbound route filtering
- RFC 1772 Application of the Border Gateway Protocol (BGP) in the Internet
- RFC 1997 BGP communities attribute
- RFC 2385 Protection of BGP sessions via the TCP MD5 signature option
- RFC 2439 BGP route flap damping
- RFC 2545 Use of BGP-4 multiprotocol extensions for IPv6 inter-domain routing
- RFC 2858 Multiprotocol extensions for BGP-4
- RFC 2918 Route refresh capability for BGP-4
- RFC 3392 Capabilities advertisement with BGP-4
- RFC 3882 Configuring BGP to block Denial-of-Service (DoS) attacks
- RFC 4271 Border Gateway Protocol 4 (BGP-4)
- RFC 4360 BGP extended communities
- RFC 4456 BGP route reflection - an alternative to full mesh iBGP
- RFC 4724 BGP graceful restart
- RFC 4893 BGP support for four-octet AS number space
- RFC 5065 Autonomous system confederations for BGP
- RFC 5492 Capabilities advertisement with BGP-4
- RFC 5925 The TCP authentication option
- RFC 6793 BGP support for four-octet AS number space
- RFC 7606 Revised error handling for BGP UPDATE messages

Cryptographic Algorithms

FIPS Approved Algorithms

Encryption (Block Ciphers):
AES (ECB, CBC, CFB and OFB Modes)
3DES (ECB, CBC, CFB and OFB Modes)

Block Cipher Modes:

CCM
CMAC
GCM
XTS

Digital Signatures & Asymmetric Key Generation:

DSA
ECDSA
RSA
Secure Hashing:
SHA-1
SHA-2 (SHA-224, SHA-256, SHA-384, SHA-512)

Message Authentication:
HMAC (SHA-1, SHA-2(224, 256, 384, 512)
Random Number Generation:
DRBG (Hash, HMAC and Counter)

Non FIPS Approved Algorithms

RNG (AES128/192/256)
DES
MD5

Ethernet Standards

- IEEE 802.1AE Media Access Control Security (MACSec)
- IEEE 802.2 Logical Link Control (LLC)
- IEEE 802.3 Ethernet
- IEEE 802.3ab1000BASE-T
- IEEE 802.3ae10 Gigabit Ethernet
- IEEE 802.3an10GBASE-T
- IEEE 802.3azEnergy Efficient Ethernet (EEE)
- IEEE 802.3ba 40GBASE-X
- IEEE 802.3bj 100GBASE-X
- IEEE 802.3by 25GBASE-X
- IEEE 802.3x Flow control - full-duplex operation
- IEEE 802.3z 1000BASE-X

IPv4 Features

- RFC 768 User Datagram Protocol (UDP)
- RFC 791 Internet Protocol (IP)
- RFC 792 Internet Control Message Protocol (ICMP)
- RFC 793 Transmission Control Protocol (TCP)
- RFC 826 Address Resolution Protocol (ARP)
- RFC 894 Standard for the transmission of IP datagrams over Ethernet networks
- RFC 919 Broadcasting Internet datagrams
- RFC 922 Broadcasting Internet datagrams in the presence of subnets
- RFC 932 Subnetwork addressing scheme
- RFC 950 Internet standard subnetting procedure
- RFC 951 Bootstrap Protocol (BootP)
- RFC 1027 Proxy ARP
- RFC 1035 DNS client
- RFC 1042 Standard for the transmission of IP datagrams over IEEE 802 networks
- RFC 1071 Computing the Internet checksum
- RFC 1122 Internet host requirements
- RFC 1191 Path MTU discovery
- RFC 1256 ICMP router discovery messages
- RFC 1518 An architecture for IP address allocation with CIDR
- RFC 1519 Classless Inter-Domain Routing (CIDR)
- RFC 1542 Clarifications and extensions for BootP
- RFC 1591 Domain Name System (DNS)
- RFC 1812 Requirements for IPv4 routers
- RFC 1918 IP addressing
- RFC 2581 TCP congestion control
- RFC 3021 Using 31-Bit Prefixes on IPv4 Point-to-Point Links

IPv6 Features

- RFC 1981 Path MTU discovery for IPv6
- RFC 2460 IPv6 specification
- RFC 2464 Transmission of IPv6 packets over Ethernet networks
- RFC 3484 Default address selection for IPv6
- RFC 3587 IPv6 global unicast address format
- RFC 3596 DNS extensions to support IPv6
- RFC 4007 IPv6 scoped address architecture
- RFC 4193 Unique local IPv6 unicast addresses
- RFC 4213 Transition mechanisms for IPv6 hosts and routers
- RFC 4291 IPv6 addressing architecture
- RFC 4443 Internet Control Message Protocol (ICMPv6)
- RFC 4861 Neighbor discovery for IPv6
- RFC 4862 IPv6 Stateless Address Auto-Configuration (SLAAC)
- RFC 5014 IPv6 socket API for source address selection
- RFC 5095 Deprecation of type 0 routing headers in IPv6
- RFC 5175 IPv6 Router Advertisement (RA) flags option
- RFC 6105 IPv6 Router Advertisement (RA) guard

Management

- AT Enterprise MIB including AMF Plus MIB and SNMP traps
- Optical DDM MIB
- SNMPv1, v2c and v3
- ANSI/TIA-1057 LLDP-Media Endpoint Detection
- IEEE 802.1AB Link Layer Discovery Protocol (LLDP)
- RFC 1155 Structure and identification of management information for TCP/IP-based Internets

RFC 1157	Simple Network Management Protocol (SNMP)
RFC 1212	Concise MIB definitions
RFC 1213	MIB for network management of TCP/IP-based Internets: MIB-II
RFC 1215	Convention for defining traps for use with the SNMP
RFC 1227	SNMP MUX protocol and MIB
RFC 1239	Standard MIB
RFC 1724	RIPv2 MIB extension
RFC 2578	Structure of Management Information v2 (SMIv2)
RFC 2579	Textual conventions for SMIv2
RFC 2580	Conformance statements for SMIv2
RFC 2674	Definitions of managed objects for bridges with traffic classes, multicast filtering and VLAN
RFC 2741	Agent extensibility (AgentX) protocol
RFC 2787	Definitions of managed objects for VRRP
RFC 2819	RMON MIB (groups 1,2,3 and 9)
RFC 2863	Interfaces group MIB
RFC 3176	sFlow: a method for monitoring traffic in switched and routed networks
RFC 3411	An architecture for describing SNMP management frameworks
RFC 3412	Message processing and dispatching for the SNMP
RFC 3413	SNMP applications
RFC 3414	User-based Security Model (USM) for SNMPv3
RFC 3415	View-based Access Control Model (VACM) for SNMP
RFC 3416	Version 2 of the protocol operations for the SNMP
RFC 3417	Transport mappings for the SNMP
RFC 3418	MIB for SNMP
RFC 3635	Definitions of managed objects for the Ethernet-like interface types
RFC 3636	IEEE 802.3 MAU MIB
RFC 4022	MIB for the Transmission Control Protocol (TCP)
RFC 4113	MIB for the User Datagram Protocol (UDP)
RFC 4188	Definitions of managed objects for bridges
RFC 4292	IP forwarding table MIB
RFC 4293	MIB for the Internet Protocol (IP)
RFC 4318	Definitions of managed objects for bridges with RSTP
RFC 4560	Definitions of managed objects for remote ping, traceroute and lookup operations
RFC 5424	The Syslog protocol
RFC 6020	YANG - A Data Modeling Language for the Network Configuration Protocol (NETCONF)
RFC 6241	Network Configuration Protocol (NETCONF)
RFC 6244	Architecture for Network Management Using NETCONF and YANG
RFC 6527	Definitions of managed objects for VRRPv3
RFC 7950	The YANG 1.1 Data Modeling Language
RFC 8040	RESTCONF Protocol

Multicast Support

Bootstrap Router (BSR) mechanism for PIM-SM	
IGMP query solicitation	
IGMP snooping (IGMPv1, v2 and v3)	
IGMP snooping fast-leave	
IGMP/MLD multicast forwarding (IGMP/MLD proxy)	
MLD snooping (MLDv1 and v2)	
PIM and PIM SSM for IPv6	
RFC 1112	Host extensions for IP multicasting (IGMPv1)
RFC 2236	Internet Group Management Protocol v2 (IGMPv2)
RFC 2710	Multicast Listener Discovery (MLD) for IPv6
RFC 2715	Interoperability rules for multicast routing protocols
RFC 3306	Unicast-prefix-based IPv6 multicast addresses
RFC 3376	IGMPv3
RFC 3590	Source address selection for the Multicast Listener Discovery (MLD) protocol
RFC 3618	Multicast Source Discovery Protocol (MSDP)
RFC 3810	Multicast Listener Discovery v2 (MLDv2) for IPv6

RFC 3956	Embedding the Rendezvous Point (RP) address in an IPv6 multicast address
RFC 3973	PIM Dense Mode (DM)
RFC 4541	IGMP and MLD snooping switches
RFC 4604	Using IGMPv3 and MLDv2 for source-specific multicast
RFC 4607	Source-specific multicast for IP
RFC 7761	Protocol Independent Multicast - Sparse Mode (PIM-SM)

Open Shortest Path First (OSPF)

OSPF link-local signaling	
OSPF MD5 authentication	
Out-of-band LSDB resync	
RFC 1245	OSPF protocol analysis
RFC 1246	Experience with the OSPF protocol
RFC 1370	Applicability statement for OSPF
RFC 1765	OSPF database overflow
RFC 2328	OSPFv2
RFC 2370	OSPF opaque LSA option
RFC 2740	OSPFv3 for IPv6
RFC 3101	OSPF Not-So-Stubby Area (NSSA) option
RFC 3509	Alternative implementations of OSPF area border routers
RFC 3623	Graceful OSPF restart
RFC 3630	Traffic engineering extensions to OSPF
RFC 4552	Authentication/confidentiality for OSPFv3
RFC 5329	Traffic engineering extensions to OSPFv3
RFC 5340	OSPFv3 for IPv6 (partial support)

Quality of Service (QoS)

IEEE 802.1p	Priority tagging
IEEE 802.1Qaz	Enhanced Transmission Selection (ETS)
IEEE 802.1Qaz	Data Center Bridging Capabilities Exchange Protocol (DCBX)
IEEE 802.1Qbb	Priority-based Flow Control (PFC)
RFC 2211	Specification of the controlled-load network element service
RFC 2474	DiffServ precedence for eight queues/port
RFC 2475	DiffServ architecture
RFC 2597	DiffServ Assured Forwarding (AF)
RFC 2697	A single-rate three-color marker
RFC 2698	A two-rate three-color marker
RFC 3246	DiffServ Expedited Forwarding (EF)

Resiliency Features

ITU-T G.8032 / Y.1344	Ethernet Ring Protection Switching (ERPS)
IEEE 802.1ag	Connectivity Fault Management (CFM), Continuity Check Protocol (CCP)
IEEE 802.1AX	Link aggregation (static and LACP)
IEEE 802.1D	MAC bridges
IEEE 802.1s	Multiple Spanning Tree Protocol (MSTP)
IEEE 802.1w	Rapid Spanning Tree Protocol (RSTP)
IEEE 802.3ad	Static and dynamic link aggregation
RFC 5798	Virtual Router Redundancy Protocol version 3 (VRRPv3) for IPv4 and IPv6

Routing Information Protocol (RIP)

RFC 1058	Routing Information Protocol (RIP)
RFC 2080	RIPng for IPv6
RFC 2081	RIPng protocol applicability statement
RFC 2082	RIP-2 MD5 authentication
RFC 2453	RIPv2

Security Features

SSH remote login	
SSLv2 and SSLv3	
IEEE 802.1X	authentication protocols (TLS, TTLS, PEAP and MD5)
IEEE 802.1X	multi-suppliant authentication
IEEE 802.1X	port-based network access control
RFC 2560	X.509 Online Certificate Status Protocol (OCSP)
RFC 2818	HTTP over TLS ("HTTPS")
RFC 2865	RADIUS authentication
RFC 2866	RADIUS accounting
RFC 2868	RADIUS attributes for tunnel protocol support

RFC 2986	PKCS #10: certification request syntax specification v1.7
RFC 3546	Transport Layer Security (TLS) extensions
RFC 3579	RADIUS support for Extensible Authentication Protocol (EAP)
RFC 3580	IEEE 802.1x RADIUS usage guidelines
RFC 3748	PPP Extensible Authentication Protocol (EAP)
RFC 4251	Secure Shell (SSHv2) protocol architecture
RFC 4252	Secure Shell (SSHv2) authentication protocol
RFC 4253	Secure Shell (SSHv2) transport layer protocol
RFC 4254	Secure Shell (SSHv2) connection protocol
RFC 5176	RADIUS Change of Authorization (CoA)
RFC 5280	X.509 certificate and Certificate Revocation List (CRL) profile
RFC 5425	Transport Layer Security (TLS) transport mapping for Syslog
RFC 5656	Elliptic curve algorithm integration for SSH
RFC 6125	Domain-based application service identity within PKI using X.509 certificates with TLS
RFC 6614	Transport Layer Security (TLS) encryption for RADIUS
RFC 6668	SHA-2 data integrity verification for SSH
RFC 8446	Transport Layer Security (TLS) v1.3
RFC 8894	Simple Certificate Enrollment Protocol (SCEP)

Services

RFC 854	Telnet protocol specification
RFC 855	Telnet option specifications
RFC 857	Telnet echo option
RFC 858	Telnet suppress go ahead option
RFC 1091	Telnet terminal-type option
RFC 1350	Trivial File Transfer Protocol (TFTP)
RFC 1985	SMTP service extension
RFC 2049	MIME
RFC 2131	DHCPv4 (server, relay and client)
RFC 2132	DHCP options and BootP vendor extensions
RFC 2616	Hypertext Transfer Protocol - HTTP/1.1
RFC 2821	Simple Mail Transfer Protocol (SMTP)
RFC 2822	Internet message format
RFC 3046	DHCP relay agent information option (DHCP option 82)
RFC 3315	DHCPv6 (server, relay and client)
RFC 3396	Encoding long options in DHCPv4
RFC 3633	IPv6 prefix options for DHCPv6
RFC 3646	DNS configuration options for DHCPv6
RFC 3993	Subscriber-ID suboption for DHCP relay agent option
RFC 4330	Simple Network Time Protocol (SNTP) version 4
RFC 4954	SMTP service extension for authentication
RFC 5905	Network Time Protocol (NTP) version 4

VLAN Support

Generic VLAN Registration Protocol (GVRP)	
IEEE 802.1ad Provider bridges (VLAN stacking, Q-in-Q)	
IEEE 802.1Q Virtual LAN (VLAN) bridges	
IEEE 802.1v VLAN classification by protocol and port	
IEEE 802.3ac VLAN tagging	
Static VXLAN tunnels (part of RFC 7348)	

Voice over IP (VoIP)

LLDP-MED ANSI/ Voice VLAN	
------------------------------	--

FEATURE LICENSES

	Description	Includes	Stack Licensing
AT-FL-x560-01	x560 Premium license	<ul style="list-style-type: none"> ■ OSPFv2 (12,000 routes)¹ ■ BGP4 (5,000 routes)¹ ■ PIMv4-SM, DM and SSM v4 ■ RIPv4 (12,000 routes) ■ OSPFv3 (12,000 routes) ■ MLDv1/v2 ■ PIM-SMv6/SSMv6 ■ VLAN double tagging (Q-in-Q) ■ VLAN Translation ■ RADIUS Full ■ VRF-Lite (64 domains) 	<ul style="list-style-type: none"> ■ One license per stack member
AT-SW-APM10-1YR²	Cumulative AMF Plus Master license	<ul style="list-style-type: none"> ■ AMF Plus Master license for up to 10 nodes for 1 year 	<ul style="list-style-type: none"> ■ One license per stack
AT-SW-APM10-5YR²	Cumulative AMF Plus Master license	<ul style="list-style-type: none"> ■ AMF Plus Master license for up to 10 nodes for 5 years 	<ul style="list-style-type: none"> ■ One license per stack
AT-SW-AWC10-1YR³	Cumulative AWC license	<ul style="list-style-type: none"> ■ Autonomous Wave Control (AWC) license for up to 10 access points for 1 year 	<ul style="list-style-type: none"> ■ One license per stack
AT-SW-AWC10-5YR³	Cumulative AWC license	<ul style="list-style-type: none"> ■ Autonomous Wave Control (AWC) license for up to 10 access points for 5 years 	<ul style="list-style-type: none"> ■ One license per stack
AT-FL-x560-AAP-1YR	AMF Application Proxy license	<ul style="list-style-type: none"> ■ AMF Application Proxy license for 1 year 	<ul style="list-style-type: none"> ■ One license per stack
AT-FL-x560-AAP-5YR	AMF Application Proxy license	<ul style="list-style-type: none"> ■ AMF Application Proxy license for 5 years 	<ul style="list-style-type: none"> ■ One license per stack
AT-FL-x560-OF13-1YR	OpenFlow license	<ul style="list-style-type: none"> ■ OpenFlow v1.3 for 1 year 	<ul style="list-style-type: none"> ■ Not supported on a stack
AT-FL-x560-OF13-5YR	OpenFlow license	<ul style="list-style-type: none"> ■ OpenFlow v1.3 for 5 years 	<ul style="list-style-type: none"> ■ Not supported on a stack
AT-FL-x560-MSEC⁴	MACSec license	<ul style="list-style-type: none"> ■ Media Access Control Security 	<ul style="list-style-type: none"> ■ One license per stack

¹ 64 OSPF and BGP routes included in base license

² Purchase one license per 10 nodes (up to 50 nodes maximum)

³ 5 APs can be managed for free. Purchase one license per 10 additional APs (up to 50 APs maximum)

⁴ MACSec is only supported on ports 1–16, and uplink ports 25–28

ORDERING INFORMATION

AT-x560-28YSQ	24-port 1/10/25G SFP28 stackable switch with 4 x 40/100G QSFP28 uplink ports, and dual fixed power supplies
AT-VT-Kit3	Management cable (USB to serial console)

Accessories

100G QSFP28 Modules		AT-QSFP1CU	1 meter QSFP+ direct attach cable
AT-QSFP28-SR4	100GSR 850 nm short-haul up to 100 m with MMF	AT-QSFP3CU	3 meter QSFP+ direct attach cable
AT-QSFP28-LR4	100GLR 1310 nm medium-haul, 10 km with SMF	25G SFP28 Modules	
AT-QSFP28-1CU	1 meter QSFP28 direct attach cable	AT-SP25SR/I	100 m, 25G SFP, LC, MMF, 850 nm, industrial temperature, TAA ⁵
AT-QSFP28-3CU	3 meter QSFP28 direct attach cable	AT-SP25LR/I	10 km, 25G SFP, LC, SMF, 1310 nm, industrial temperature, TAA ⁵
40G QSFP+ Modules		AT-SP25TW1	1 m, 25G SFP, direct attach cable
AT-QSFPSR4	40GSR4 850nm short-haul up to 150 m with MMF, MPO-12	AT-SP25TW3	3 m, 25G SFP, direct attach cable
AT-QSFPSR4LCa	40GSR4 850 nm short-haul up to 150 m with MMF, LC	10GbE SFP+ Modules	
AT-QSFPLR4	40GLR4 1310 nm medium-haul, 10 km with SMF	AT-SP10SR	10GSR 850 nm short-haul, 300 m with MMF
AT-QSFPER4	40GER4 1310 nm long-haul, 40 km with SMF	AT-SP10SR/I	10GSR 850 nm short-haul, 300 m with MMF industrial temperature

⁵ Trade Act Agreement compliant

10GbE SFP+ Modules	
AT-SP10LRM	10GLRM 1310 nm short-haul, 220 m with MMF
AT-SP10LR	10GLR 1310 nm medium-haul, 10 km with SMF
AT-SP10LRa/I	10GLR 1310 nm medium-haul, 10 km with SMF industrial temperature
AT-SP10ER40a/I	10GER 1310 nm long-haul, 40 km with SMF industrial temperature
AT-SP10ZR80/I	10GER 1550 nm long-haul, 80 km with SMF industrial temperature
AT-SP10TM/I	1G/2.5G/5G/10G, 100 m copper, industrial temperature, TAA ⁵
AT-SP10TW1	1 meter SFP+ direct attach cable
AT-SP10TW3	3 meter SFP+ direct attach cable
AT-SP10TW7	7 meter SFP+ direct attach cable

1000Mbps SFP Modules	
AT-SPSX/I	1000SX GbE multi-mode 850 nm fiber up to 550 m industrial temperature
AT-SPTX	10/100/1000T 100 m copper
AT-SPSX	1000SX GbE multi-mode 850 nm fiber up to 550 m
AT-SPEX	1000X GbE multi-mode 1310 nm fiber up to 2 km
AT-SPLX10a	1000LX GbE single-mode 1310 nm fiber up to 10 km, TAA ⁵
AT-SPLX10a/I	1000LX GbE single-mode 1310 nm fiber up to 10 km industrial temperature
AT-SPBD10-13	1000LX GbE Bi-Di (1310 nm Tx, 1490 nm Rx) fiber up to 10 km
AT-SPBD10-14	1000LX GbE Bi-Di (1490 nm Tx, 1310 nm Rx) fiber up to 10 km
AT-SPLX40	1000LX GbE single-mode 1310 nm fiber up to 40 km
AT-SPZX80	1000ZX GbE single-mode 1550 nm fiber up to 80 km

⁵ Trade Act Agreement compliant