

TQ7613-R

Wi-Fi 7 (802.11be) Wireless Access Point

Allied Telesis TQ7613-R Wi-Fi 7 access point features a 3 radio design supporting 2.4GHz, 5GHz, and 6GHz bands, with a raw capacity of up to 19 Gigabits—and it runs the Enterprise-class AlliedWare Plus operating system.

Overview

The TQ7613-R Wi-Fi 7 AP is designed to elevate enterprise connectivity to unprecedented levels, as it offers significantly higher data rates, improved capacity, and reduced latency compared to previous Wi-Fi generations. Enjoy seamless streaming, VR applications, and browse without interruption in any environment.

High-performance is ensured with a 3 radio design (4x4 2.4GHz, 4x4 5GHz, and 4x4 6GHz), with simultaneous use of each of the 3 bands for high capacity and speed up to 19 Gigabits. All 3 bands use an internal antenna for increased radio efficiency and throughput.

The TQ7613-R runs the Enterprise-class AlliedWare Plus operating system, for a consistent user-experience across the network with Allied Telesis switches, firewalls, and routers. An Industry standard command-line interface, the preinstalled Device GUI, and centralized administration from the Autonomous Wave Control (AWC) wireless controller built-in to Vista Manager™, provide flexible management options.

Autonomous Management Framework™ Plus (AMF Plus) provides automated backup of firmware, configuration, and licenses to the network master device, enabling plug-and-play recovery—along with other powerful features such as auto- upgrade, and auto-provisioning for zero-touch network roll-out.

Flexible installation options include desktop use, and wall or ceiling mounting. Power can be supplied by Power over Ethernet, or by an optional AC power adapter.

KEY FEATURES

Wi-Fi 7

IEEE 802.11be Wi-Fi 7 connectivity delivers ultra-high performance compared to older Wi-Fi standards. Support for Improved modulation, an increased number of streams, and superior bandwidth use, increase the maximum transmission rate up to 36 Gbps.

New features such as Multi-Link Operation (MLO) improve communication latency and stability, and provide efficient bandwidth use in crowded wireless environments.

Use of the 6GHz band (up to 320 MHz) and 4096QAM frequency management allows more devices to connect and provides stable high throughput. With support for increased numbers of clients, and optimization for high-bandwidth and real-time applications like streaming video, the TQ7613-R is ideal for education, healthcare, manufacturing, and commercial environments.

Standalone Management

The TQ7613-R can be managed standalone using the AlliedWare Plus industry-standard command line, or the intuitive pre-installed Device GUI.

Centralized Management

For smaller networks, the Device GUI includes a wireless controller which enables the TQ7613-R to

manage itself and up to 50 other APs, for an all-in-one Wi-Fi monitoring and management solution.

For larger networks, multiple APs can be centrally managed using the Autonomous Wave Control (AWC) wireless controller built-in to Vista Manager. Enjoy seamless visibility of APs alongside switches, firewalls, third-party, and endpoint devices.

AWC regularly analyses the Wi-Fi network, automatically optimizing wireless settings to reduce interference and minimize coverage gaps—all with no user intervention.

All units are automatically backed-up using Autonomous Management Framework Plus (AMF Plus), and can be restored with plug-and-play simplicity.

Vista Manager, AMF Plus, and AWC provide visual and automated management that greatly reduces the time and cost of managing multiple APs in larger deployments.

Non-stop Wi-Fi

Even if APs lose connectivity to the AWC wireless controller, they will continue to provide connectivity to user devices and forward traffic, ensuring no interruption to business operation.

Deep Packet Inspection (DPI) statistics

DPI enables application statistics to be gathered from the wireless edge, showing the most used applications.

Vista Manager displays application statistic with an informative Top-10 applications list and pie-chart, which can be viewed with statistics from the last hour, or up to the last 24-hours.

Selecting multiple APs shows aggregated statistics, useful for monitoring the wireless edge of different areas of the network.

Captive Portal

Manage user access to outdoor public space Wi-Fi networks with captive portal. New users are taken to a login page to authenticate before gaining online access.

Login options include direct online access, external authentication, or redirection to third party services—for example social media sites like Facebook.

Passpoint® and OpenRoaming

Wi-Fi Alliance certified Passpoint enables auto-detection and connection of client devices, removing the need for users to find and authenticate on wireless networks. This provides a flexible Wi-Fi network with a high level of security.



OpenRoaming is an international Wi-Fi interoperability standard allowing devices using an applicable profile to automatically connect to OpenRoaming-compliant networks. This ensures ease of use, as well as avoiding security risks such as virus infection and data theft due to misconnection. The TQ7613-R can be used to deploy OpenRoaming-compliant Wi-Fi networks in public facilities and event venues.

QR codes simplify wireless connectivity

Generate a QR code on the AP that can be scanned by smartphones and other wireless devices to enable quick and easy connection to the Wi-Fi network, eliminating the need to enter SSIDs and passwords.

Virtual APs with Multiple SSIDs

The TQ7613-R support Virtual AP (VAP) functionality, with the assignment of different SSIDs and security policies for each VAP on the device.

VAPs can be mapped to VLANs for logical network separation and improved throughput. Enable communication by application, function or users.

Fast Roaming

Fast roaming 802.11k, 802.11v, and 802.11r optimize discovering and selecting the best available AP in a Wi-Fi network. It establishes rapid connectivity for users to seamlessly move between APs, as the APs exchange security keys, so the client device does not need to re-authenticate on the RADIUS server as they roam.

Wi-Fi Scheduling

Radio signal strength on the AP can be scheduled to suit the time of day, with different levels at different times. For example, turning off radio signals late at night, when the Wi-Fi network may not be in use, can prevent unauthorized access and save power.

AMF-Security and Application Proxy¹

The AMF-Security (AMF-Sec) solution enables internal LAN threat detection and automatic end-point isolation to protect the network. If a firewall detects suspicious traffic or a threat such as a virus from a wireless device, it informs the AMF-Sec controller, which uses the AMF Application Proxy to communicate and enable to AP to block or quarantine the infected user device. This automatically protects the network from threats.

¹ An AMF-Security controller, and Vista Manager AWC wireless management are required

SPECIFICATIONS

Wireless

- Airtime fairness
- Automatic channel selection
- Automatic control of transmission power
- Band Steering
- Beam forming
- Bi-directional Multi-user MIMO
- Fast roaming
- Multiple Link Operation(MLO)
- OFDMA
- Passpoint (Hotspot 2.0)
- RF load balancing
- VLAN (VAP (recommended 5 or less for 2.4GHz/5GHz/6GHz respectively)/Dynamic VLAN)
- Wi-Fi Multimedia (WMM) for traffic prioritization
- Wi-Fi Scheduling
- Wireless Distribution System (WDS)

Physical Specifications

	Width	Depth	Height	Radios	Weight	100M/1G/2.5G/5G/10G (RJ-45) copper ports
TQ7613-R	265 mm (10.44 in)	265 mm (10.44 in)	45 mm (1.78 in)	4 x 4 (2.4GHz) 4 x 4 (5GHz) 4 x 4 (6GHz)	1.6 kg (3.53 lbs)	2 (PoE-in port)

Power Characteristics

	Power Supply	Average Power Consumption	Maximum Power Consumption	Max Heat Dissipation
TQ7613-R	100~240VAC	32.0W	43.5W	148.3 BTU/h
	PoE	32.0W	43.5W	148.3 BTU/h

- Zero Wait DFS
- Wireless QoS

Operational Modes

- Centrally managed by Vista Manager EX (up to 3,000 APs)
- Centrally managed by Vista Manager Network Appliance (VST-APL) (up to 500 APs)
- Standalone (supports up to 500 clients per radio for 2.4GHz/5GHz/6GHz)

Management

- Autonomous Management Framework Plus (AMF Plus) automates network administration, with powerful features like zero-touch device installation and recovery.
- Autonomous Wave Control (AWC) provides centralized AP management, as well as automated wireless network optimization for a superior user experience.
- NETCONF/RESTCONF northbound interface with YANG data modelling
- Industry-standard CLI with context-sensitive help
- Built-in Device GUI
- Simple Network Management Protocol (SNMPv1, v2c, v3)
- Firmware upgrade
- Backup/restore settings
- Syslog notification
- Built-in packet capture
- DHCP client
- NTP client
- Event-based triggers allow user-defined scripts to be executed upon selected system events
- Comprehensive logging to local memory and syslog
- Compatible with AMF-Security, and AT-RADGate (Allied Telesis RADIUS server)

Security

- Authentication and Accounting
 - Open System Authentication
 - Enhanced Open Authentication
 - IEEE 802.1X Authentication and Accounting
 - IEEE 802.1X RADIUS support
 - Shared Key Authentication
 - WPA (Enterprise, Personal)
 - WPA2 (Enterprise, Personal)
 - WPA3 (Enterprise, Personal)

Captive Portal (External RADIUS, Click-Through, Redirection Page, Virtual IP Address, RADIUS Accounting, Walled Garden)

Wi-Fi Alliance certified Passpoint® enables auto-detection and connection of client device

- Encryption
 - WEP: 64/128 bit (IEEE 802.11a/b/g only)
 - WPA/WPA2: CCMP (AES), TKIP
 - WPA3: CCMP/GCMP (AES/CNSA)
- MAC address filtering (Up to 3072 MAC address)
- SSID hiding/ignoring
- Client isolation
- Neighbor AP detection
- Hardware TPM
- Kensington lock
- Simple Certificate Enrollment Protocol (SCEP) supports secure management

Compliance

Certificate

- Wi-Fi certified
- CE
- SIRIM (For Malaysia)
- ARIB STD T-66 / T-71)

Safety

- EN 62368-1
- UL 62368-1
- UL 2043

ElectroMagnetic Compatibility

- EN 301 489-1
- EN 301 489-17
- EN 55032, Class B
- EN 55035
- EN 60601-1-2
- EN 61000-3-2, Class A
- EN 61000-3-3
- EN 61000-4-2
- EN 61000-4-3
- EN 61000-4-4
- EN 61000-4-5
- EN 61000-4-6
- EN 61000-4-8
- EN 61000-4-11
- VCCI Class B

Radio equipment

- EN 300 328
- EN 301 893
- EN 303 687

Environmental Specifications

- Operating temperature range:
0°C to 50°C (32°F to 122°F)
- Storage temperature range:
-25°C to 70°C (-13°F to 158°F)
- Operating relative humidity range:
5% to 95% non-condensing
- Storage relative humidity range:
5% to 95% non-condensing
- Operating altitude range:
Up to 3,048 meters maximum (10,000 ft)

Embedded Antennas

Omni-directional

- Frequency band: 2.4 GHz
- Max. peak gain: <4.5 dBi

Omni-directional

- Frequency band: 5 GHz
- Max. peak gain: <6 dBi

Omni-directional

- Frequency band: 6 GHz
- Max. peak gain: <6 dBi

Radio Characteristics

Supported frequencies:

- 2.412 ~ 2.472 GHz
- 5.150 ~ 5.250 GHz
- 5.250 ~ 5.350 GHz
- 5.500 ~ 5.720 GHz
- 5.745 ~ 5.825 GHz (Not supported in EMEA)
- 5.925 ~ 6.425 GHz

Modulation Technique

- 802.11a/g/n/ac: OFDM
- 802.11 ax:/be OFDMA
- 802.11b: DSSS, CCK, DQPSK, DBPSK
- 802.11ac: BPSK, QPSK, 16QAM, 64QAM, 256QAM
- 802.11a/g/n: BPSK, QPSK, 16QAM, 64QAM, 256QAM
- 802.11 ax: BPSK, QPSK, 16QAM, 64QAM, 256QAM, 1024QAM
- 802.11 be: BPSK, QPSK, 16QAM, 64QAM, 256QAM, 1024QAM, 4096QAM

Data Rate

- IEEE802.11b 11/5.5/2./1Mbps
- IEEE 802.11a/g 54/48/36/24/18/12/9/6Mbps
- IEEE 802.11n (2.4GHz) up to 800Mbps
- IEEE 802.11ax (2.4GHz) up to 1,147Mbps
- IEEE 802.11be (2.4GHz) up to 1,376Mbps
- IEEE 802.11n (5GHz) up to 600Mbps
- IEEE 802.11ac (5GHz) up to 1,733Mbps
- IEEE 802.11ax (5GHz) up to 2,402Mbps
- IEEE 802.11be 5GHz up to 5,764Mbps
- IEEE 802.11ax 6GHz up to 4,804Mbps
- IEEE 802.11be 6GHz up to 11,529Mbps

Media Access

- CSMA/CA + Ack with RTS/CTS

Diversity

- Spatial diversity

Diagnostic Tools

- Automatic link flap detection and port shutdown
- Ping polling for IPv4 and IPv6
- TraceRoute for IPv4 and IPv6

Authentication

- Strong password security and encryption
- Local RADIUS server for up to 100 users
- TACACS+ authentication and authorization
- IEEE 802.1x authentication on LAN ports

STANDARDS & PROTOCOLS

Ethernet Standards

- IEEE 802.3u 100BASE-TX
- IEEE 802.3ab 1000BASE-T
- IEEE 802.3bz 2.5GBASE-T/5GBASE-T
- IEEE 802.3an 10GBASE-T
- IEEE 802.3at Power over Ethernet +
- IEEE 802.3x Flow Control
- IEEE 802.3bt Power over Ethernet++
- IEEE 802.1Q VLAN Tagging
- IEEE 802.1AX-2008 Link Aggregation (static and dynamic)

Wireless

- IEEE 802.11 a/b/g/n/ac/ax/be 4x4:4ss MU-MIMO
- IEEE 802.11k Radio Resource Measurement of Wireless LANs
- IEEE 802.11v Basic Service Set Transition Management Frames
- IEEE 802.11r Fast Basic Service Set Transition

Radiation Patterns for Wi-Fi 2GHz

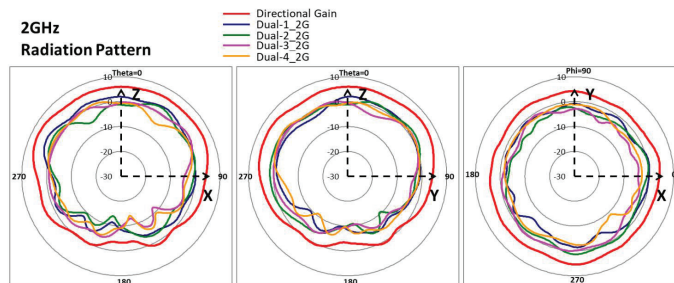

Radiation Patterns for Wi-Fi 5GHz

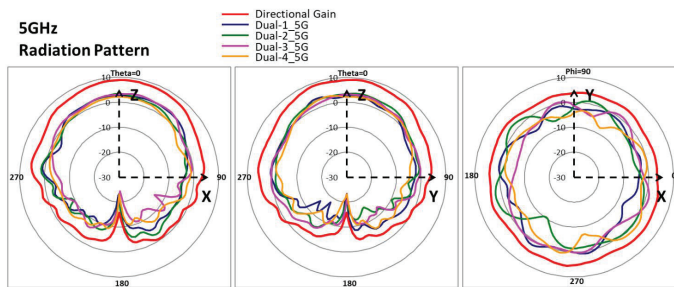

Radiation Patterns for Wi-Fi 6GHz

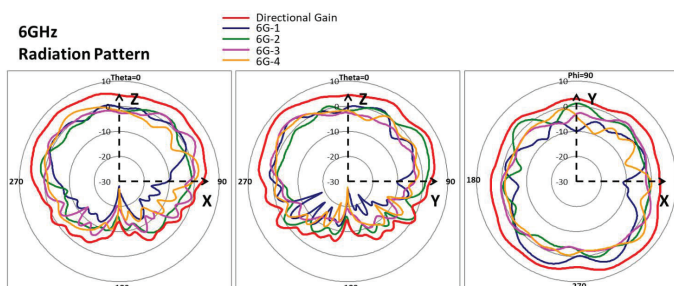

AP LEDs

Informative LEDs provide at-a-glance status of AP activity

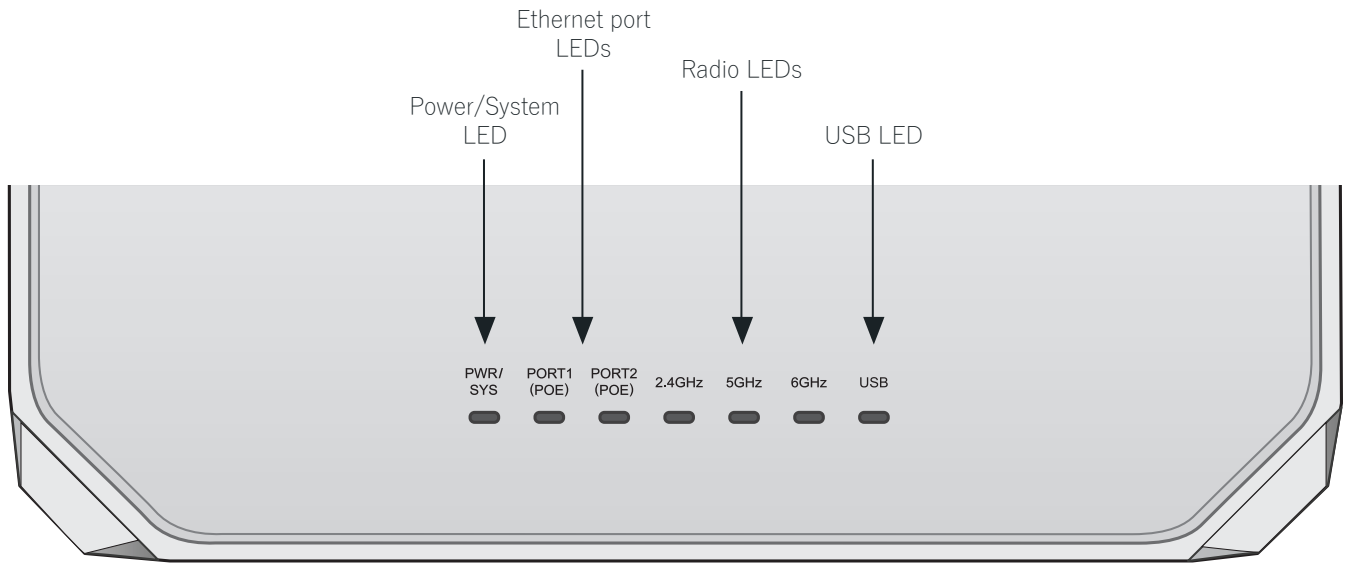

AP Connectivity

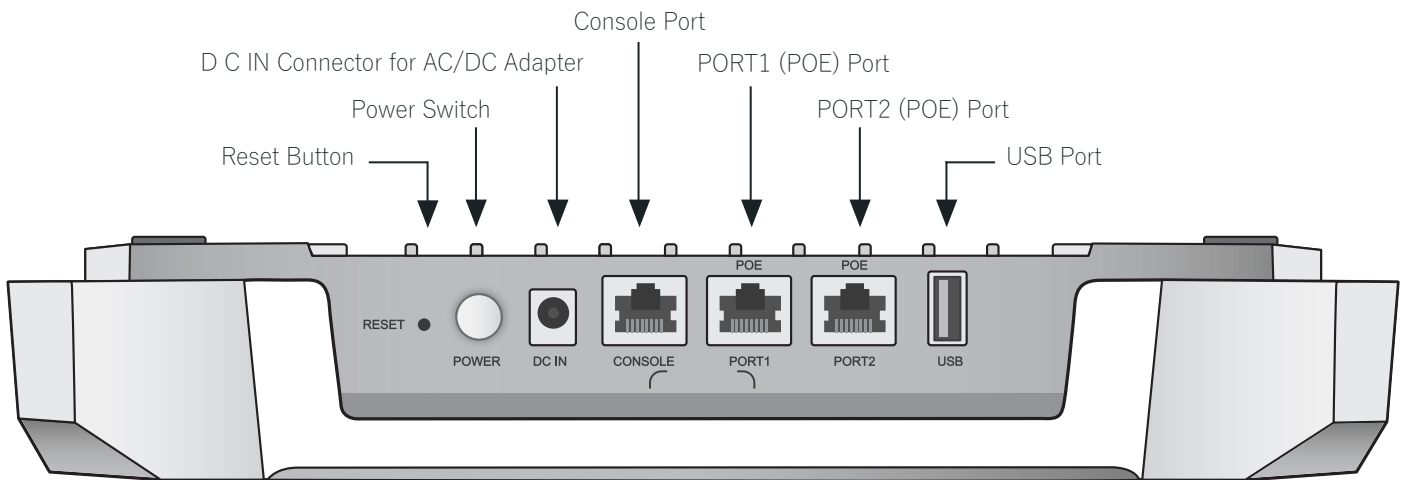

Wi-Fi PLANNING

Need help planning your wireless network? See our handy [Wi-Fi planner](#).



LICENSES

Wireless Management Licenses

Wireless management of APs is available from the Vista Manager EX network management platform, and from the wireless controller in the Device GUI on the switch and firewall products listed in the following table.

platform	license Name	Description	max supported aps
Vista Manager EX	AT-FL-VISTA-BASE-1/5YR	Vista Manager EX network monitoring and management software license	NA
Vista Manager EX (Windows)	AT-FL-VISTA-AWC10-1/5YR ²	Vista Manager AWC plug-in license for managing up to 10 access points	3000
Vista Manager EX (Virtual (VRT))	AT-FL-VISTA-AWC10-1/5YR ²	Vista Manager AWC plug-in license for managing up to 10 access points	500
Vista Manager EX (Network Appliance)	AT-FL-VISTA-AWC10-1/5YR ²	Vista Manager AWC plug-in license for managing up to 10 access points	500
SwitchBlade x908 GEN2	AT-SW-AWC10-1/5YR ³	Cumulative Autonomous Wave Controller (AWC) license for up to 10 access points	305
x950 Series	AT-SW-AWC10-1/5YR ³	Cumulative Autonomous Wave Controller (AWC) license for up to 10 access points	185
x930 Series	AT-SW-AWC10-1/5YR ³	Cumulative Autonomous Wave Controller (AWC) license for up to 10 access points	125
x550 Series	AT-SW-AWC10-1/5YR ³	Cumulative Autonomous Wave Controller (AWC) license for up to 10 access points	45
x540L Series	AT-SW-AWC10-1/5YR ³	Cumulative Autonomous Wave Controller (AWC) license for up to 10 access points	45
x530 Series	AT-SW-AWC10-1/5YR ³	Cumulative Autonomous Wave Controller (AWC) license for up to 10 access points	45
ARX200S-GTX	AT-RT-AWC10-1/5YR ⁴	Cumulative Autonomous Wave Control (AWC) license for up to 10 access points	50
AR4050S UTM Firewall	AT-RT-AWC5-1/5YR ³	Cumulative Autonomous Wave Controller (AWC) license for up to 5 access points	25

² The AWC plug-in requires an AWC license, and a Vista Manager EX base license to operate on Vista Manager EX

³ 5 APs can be managed for free. Purchase one license per 10 additional APs on switches, or one license per 5 additional APs on the AR4050S Firewall.

⁴ 20 APs can be managed for free on the ARX200S-GTX, and an additional 30 APs with a license.

ORDERING INFORMATION

AT-TQ7613-R-xx ⁵	Enterprise-Class Wi-Fi 7 AP with 3 radios (4x4 2.4GHz and 4x4 5GHz and 4x4 6GHz), and embedded antenna, TAA ⁶
-----------------------------	--

Where xx = 05 Regulatory Domain: Malaysia
00 Regulatory Domain: Europe

⁵ Check for availability in your region
⁶ Trade Act Agreement compliant

Related Products

AT-PWRADP-01	AC adapter for TQ7613-R
AT-7101GHTm-yy ⁷	Multi-Gigabit Ethernet PoE++ (802.3bt) injector
AT-BRKT-CONV-AP1	Replacement bracket converter

Where yy = 10 for US power cord
30 for UK power cord
40 for Australian power cord
50 for European power cord

⁷ The Gigabit Ethernet PoE+ injector can also be used (AT-6101GP), but note that the AP will run in low-power mode with some limitations, and reduced data speeds - see the installation guide for details