

x230 Series

Enterprise Gigabit Edge Switches

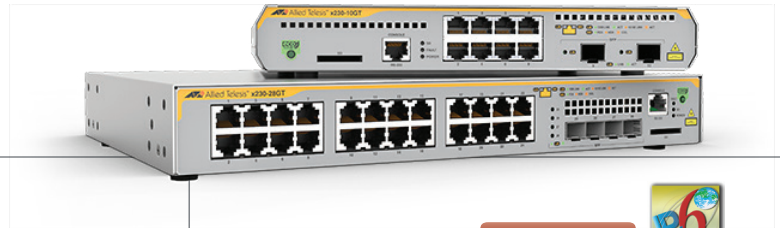

Overview

Allied Telesis x230 Series switches provide an excellent access solution for today's networks, supporting Gigabit to the desktop for maximum performance. The Power over Ethernet Plus (PoE+) models provide an ideal solution for connecting and remotely powering wireless access points, IP video surveillance cameras, and IP phones. With 8, 16 or 24 Gigabit ports, SFP uplinks, and fanless models for silent operation, the x230 Series enable flexible deployment and secure connectivity at the network edge.

Secure

Network Access Control (NAC) gives unprecedented control over user access to mitigate threats to network infrastructure.

Allied Telesis x230 switches use 802.1x port-based authentication, in partnership with standards-compliant dynamic VLAN assignment, to assess a user's adherence to network security policies and either grant access or offer remediation. Tri-authentication ensures the network is only accessed by known users and devices. Secure access is also available for guests.

Security from malicious network attacks is provided by a comprehensive range of features such as DHCP snooping, STP root guard, BPDU protection and access control lists. Each of these can be configured to perform a variety of actions upon detection of a suspected attack.

Network protection

Advanced storm protection features include bandwidth limiting, policy-based storm protection and packet storm protection.

Network storms are often caused by cabling errors that result in a network loop. Allied Telesis x230 Series switches provide features to detect loops as soon as they are created. Loop detection and thrash limiting take immediate action to prevent network storms.

Manageable

The advanced AlliedWare Plus™ fully featured operating system delivers a rich feature set and an industry-standard Command Line Interface (CLI). This reduces training requirements and is consistent across all AlliedWare Plus devices, simplifying network management.

The web-based Graphical User Interface (GUI) is an easy-to-use and powerful management tool, with comprehensive monitoring facilities.

Future-proof

x230 Series switches are Software Defined Networking (SDN) ready and able to support OpenFlow v1.3.

Network management

Vista Manager™ EX bundled with Allied Telesis Autonomous Management Framework™ Plus (AMF Plus) meets the increasing management requirements of modern networks. While AMF Plus allows an entire network to be securely and easily managed as a single virtual device, Vista Manager EX provides an intuitive and powerful graphical tool for monitoring and managing AMF Plus wired, Autonomous Wave Control (AWC) wireless, and third party (SNMP) devices.

Cybersecurity

The x230 Series acting as an AMF Plus member is compatible with our AMF-Security solution, which enables a self-defending network. The AMF-Sec controller



Key Features

- AMF Plus secure mode
- AMF-Security compatible
- VLAN ACLs
- TACACS+ Command Authorization
- Active Fiber Monitoring
- OpenFlow for SDN
- VLAN Mirroring (RSPAN)
- Precision Time Protocol (PTP) Transparent Mode
- Fanless models provide silent operation
- G.8032 Ethernet Ring Protection
- Link Monitoring
- Upstream Forwarding Only (UFO)
- NETCONF/RESTCONF with YANG data modelling

responds immediately to any internal malware threats by instructing the x230 Series to isolate the affected part of the network, and quarantine the suspect device. Vista Manager EX alerts networks administrators of threats that have been dealt with.

ECO friendly

The x230 Series supports Energy Efficient Ethernet, which automatically reduces the power consumed by the switch whenever there is no traffic on a port. This sophisticated feature can significantly reduce your operating costs by reducing the power requirements of the switch and any associated cooling equipment.

The x230-10GT and x230L models are fanless, providing silent operation, which makes them ideal for desktop or work area deployment.

KEY FEATURES

Autonomous Management Framework™ Plus (AMF Plus)

AMF Plus is a sophisticated suite of management tools that provide a simplified approach to network management. Common tasks are automated or made so simple that the every-day running of a network can be achieved without the need for highly-trained, and expensive, network engineers. Powerful features like centralized management, auto-backup, auto-upgrade, auto-provisioning and auto-recovery enable plug-and-play networking and zero-touch management.

AMF Plus secure mode encrypts all AMF traffic, provides unit and user authorization, and monitors network access to greatly enhance network security.

From AW+ 5.5.2-2 onwards, an AMF Plus license operating in the network provides all standard AMF network management and automation features, and also enables the AMF Plus intent-based networking features in Vista Manager EX (from version 3.10.1 onwards).

Power over Ethernet Plus (PoE+)

With PoE, a separate power connection to media endpoints such as IP phones and wireless access points is not necessary. PoE+ reduces costs and provides even greater flexibility, providing the capability to connect devices requiring more power (up to 30 Watts) such as tilt and zoom security cameras.

Ethernet Protection Switched Ring (EPSRing™)

EPSRing allows several x230 switches to join a protected ring capable of recovery within as little as 50ms. This feature is perfect for high availability in enterprise networks.

G.8032 Ethernet Ring Protection

G.8032 provides standards-based high-speed ring protection, that can be deployed stand-alone, or interoperate with Allied Telesis EPSR.

Ethernet Connectivity Fault Monitoring (CFM) proactively monitors links and VLANs, and provides alerts when a fault is detected.

Access Control Lists (ACLs)

ACLs filter network traffic to control whether routed packets are forwarded or blocked, and can be applied to a specific port or a VLAN. This provides a powerful network security mechanism to select the types of traffic to be analyzed, forwarded, or influenced in some way.

NETCONF/RESTCONF

NETCONF/RESTCONF with YANG data modeling provides a standardized way to represent data and securely configure devices.

Easy To Manage

The AlliedWare Plus operating system incorporates an industry standard CLI, facilitating intuitive manageability.

With three distinct modes, the CLI is very secure, and the use of SSHv2 encrypted and strongly authenticated remote login sessions ensures CLI access is not compromised.

As a Layer 2+ switch, a static route can be added to allow a user in a different subnet to manage the switch.

Storm protection

Advanced packet storm control features protect the network from broadcast storms:

Bandwidth limiting minimizes the effects of the storm by reducing the amount of flooding traffic.

Policy-based storm protection is more powerful than bandwidth limiting. It restricts storm damage to within the storming VLAN, with a defined traffic rate. The action the device should take when it detects a storm can be configured, such as disabling the port from the VLAN or shutting the port down.

Loop protection

Thrash limiting, also known as Rapid MAC movement, detects and resolves network loops. It is highly user-configurable – from the rate of looping traffic to the type of action the switch should take when it detects a loop.

With thrash limiting, the switch only detects a loop when a storm has occurred, which can potentially cause disruption to the network. To avoid this, loop detection works in conjunction with thrash limiting to send special packets, called Loop Detection Frames (LDF), that the switch listens for. If a port receives an LDF packet, one can choose to disable the port, disable the link, or send an SNMP trap.

Spanning Tree Protocol (STP) Root Guard

STP root guard designates which devices can assume the root bridge role in an STP network. This stops an undesirable device from taking over this role, where it could either compromise network performance or cause a security weakness.

Bridge Protocol Data Unit (BPDU) protection

BPDU protection adds extra security to STP. It protects the spanning tree configuration by preventing malicious DoS attacks caused by spoofed BPDUs. If a BPDU packet is received on a protected port, the BPDU protection feature disables the port and alerts the network manager.

sFlow

sFlow is an industry-standard technology for monitoring high-speed switched networks. It provides complete visibility into network use, enabling performance optimization, usage accounting/billing, and defense against security threats. Sampled packets sent to a collector (up to 5 collectors can be configured) ensure a real-time view of network traffic.

Tri-authentication

Authentication options include 802.1x port authentication, web authentication for guest access, and MAC authentication for end points without an 802.1x supplicant. All three can be used simultaneously.

Upstream Forwarding Only (UFO)

UFO lets you manage which ports in a VLAN can communicate with each other, and which only have upstream access to services, for secure multi-user deployment.

TACACS+ Command Authorization

TACACS+ Command Authorization offers centralized control over which commands may be issued by each specific AlliedWare Plus device user. It complements authentication and accounting services for an AAA solution.

UniDirectional Link Detection

UniDirectional Link Detection (UDLD) is useful for monitoring fiber-optic links between two switches that use two single-direction fibers to transmit and receive packets. UDLD prevents traffic from being sent across a bad link by blocking the ports at both ends of the link in the event that either the individual transmitter or receiver for that connection fails.

Optical DDM

Most modern optical SFP/SFP+/XFP transceivers support Digital Diagnostics Monitoring (DDM) functions according to the specification SFF-8472. This enables real time monitoring of the various parameters of the transceiver, such as optical output power, temperature, laser bias current and transceiver supply voltage. Easy access to this information simplifies diagnosing problems with optical modules and fiber connections.

Active Fiber Monitoring

AFM prevents eavesdropping on fiber data or stacking links by monitoring received optical power. If an intrusion is detected, the link can be automatically shut down, or an alert sent.

VLAN Mirroring (RSPAN)

VLAN mirroring allows traffic from a port on a remote switch to be analyzed locally. Traffic being transmitted or received on the port is duplicated and sent across the network on a special VLAN.

Find Me

In busy server rooms comprised of a large number of equipment racks, it can be quite a job finding the correct switch quickly among many similar units. The "Find Me" feature is a simple visual way to quickly identify the desired physical switch for maintenance or other purposes, by causing its LEDs to flash in a specified pattern.

Precision Time Protocol (PTP)

PTP (IEEE 1588v2) synchronizes clocks throughout the network with micro-second accuracy, supporting industrial automation and control systems.

Flexible deployment

The x230-10GT and x230L models are fanless for silent operation. This enables switch placement in work spaces and on desktops with no interruption to network users.

Link Monitoring (Linkmon)

Linkmon enables network health monitoring by regularly sending probes over key links to gather metrics comprising latency, jitter, and probe loss. This supports pro-active network management, and can also be used with triggers to automate a change to device or network configuration in response to the declining health of a monitored link.

KEY SOLUTIONS

Network

Network convergence

The convergence of network services in the Enterprise has led to increasing demand for highly available networks with minimal downtime. Diagram 1 shows x230 switches with high performance EPSR connectivity to the x930 VCStack core. This topology provides recovery in as little as 50ms, if required.

Network flexibility

Flexible network deployment is facilitated by the compact 10 and 18 port x230 PoE+ models, as shown in the Campus network in diagram 2. With the growth of wireless networking and digital security, the x230 PoE+ models are ideal supplying connectivity and power at the network edge, supporting the full 30 watts of PoE+. The fanless x230L models provide silent operation to enable deployment in work areas.

AMF Plus provides an easy yet powerful solution for managing multiple devices with plug-and-play simplicity.

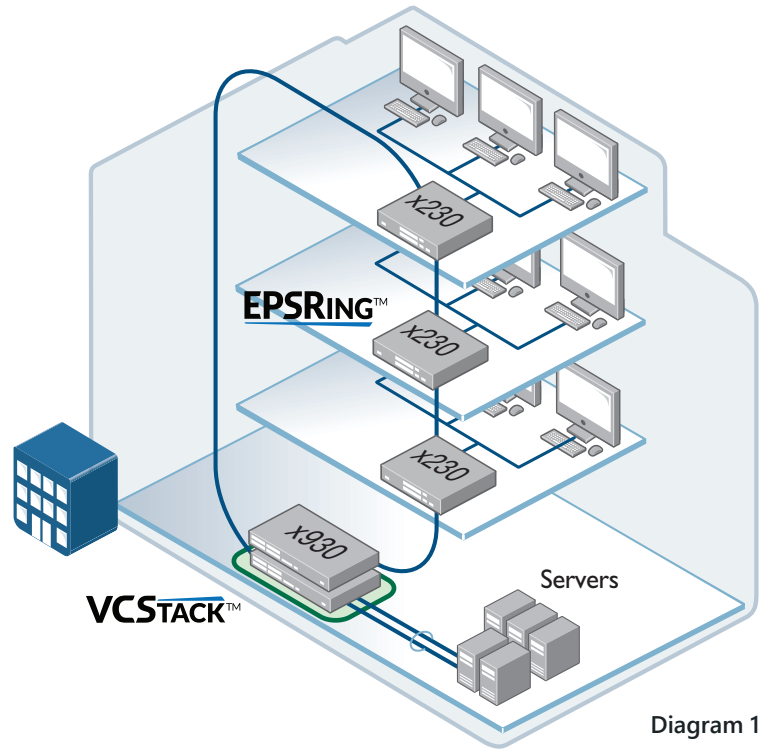
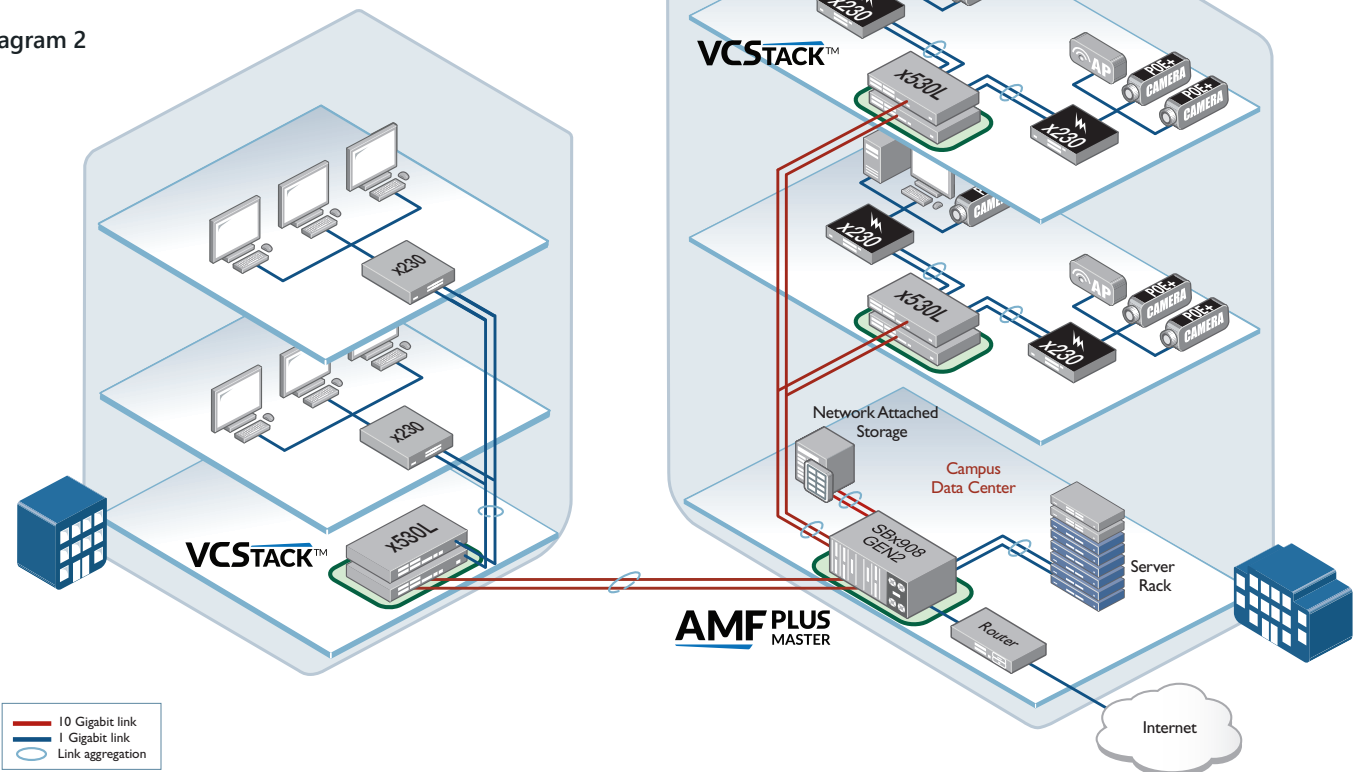

Diagram 1

Diagram 2



SPECIFICATIONS

Product Specifications

	10/100/1000T (RJ-45) Copper Ports	100/1000X SFP Ports	Total Ports	PoE Enabled Ports	Switching Fabric	Forwarding Rate
x230-10GP	8	2	10	8	20Gbps	14.9Mpps
x230-10GT	8	2	10	-	20Gbps	14.9Mpps
x230-18GP	16	2	18	16	36Gbps	26.8Mpps
x230-18GT	16	2	18	-	36Gbps	26.8Mpps
x230-28GP	24	4	28	24	56Gbps	41.7Mpps
x230-28GT	24	4	28	-	56Gbps	41.7Mpps
x230L-17GT	16	1	17	-	34Gbps	25.3Mpps
x230L-26GT	24	2	26	-	52Gbps	38.7Mpps

Latency (microseconds)

	Port Speed		
	10Mbps	100Mbps	1Gbps
x230-10GP	56.5µs	9.4µs	3.4µs
x230-10GT	68.1µs	9.4µs	3.8µs
x230-18GP/GT	46µs	7.2µs	3.6µs
x230-28GP/GT	64.31µs	9.7µs	4.3µs
x230L-17GT	46µs	7.2µs	3.6µs
x230L-26GT	64.3µs	9.72µs	4.3µs

Physical Specifications

	Width	Depth	Height	Unpacked Weight	Packaged Weight	Packaged Dimensions
x230-10GP	210 mm (8.27 in)	275 mm (10.83 in)	42.5 mm (1.67 in)	2.1 kg (4.6 lb)	3.1 kg (6.8 lb)	430 x 260 x 100 mm (16.93 x 10.24 x 3.94 in)
x230-10GT	263 mm (10.35 in)	179 mm (7.04 in)	38 mm (1.49 in)	0.7 kg (0.77 lb)	1.9 kg (4.2 lb)	460 x 260 x 110 mm (18.11 x 10.24 x 4.33 in)
x230-18GP	341 mm (13.42 in)	231 mm (9.09 in)	44 mm (1.73 in)	3.0 kg (6.6 lb)	4.4 kg (9.7 lb)	520 x 350 x 110 mm (20.47 x 13.78 x 4.33 in)
x230-18GT	341 mm (13.42 in)	231 mm (9.09 in)	44 mm (1.73 in)	2.4 kg (5.3 lb)	3.7 kg (8.2 lb)	530 x 350 x 110 mm (20.87 x 13.78 x 4.33 in)
x230-28GP	440 mm (17.32 in)	290 mm (11.42 in)	44 mm (1.73 in)	4.7 kg (10.4 lb)	6.1 kg (13.4 lb)	540 x 370 x 110 mm (21.26 x 14.57 x 4.33 in)
x230-28GT	341 mm (13.42 in)	231 mm (9.09 in)	44 mm (1.73 in)	2.4 kg (5.3 lb)	4.2 kg (9.3 lb)	520 x 350 x 120 mm (20.47 x 13.78 x 4.72 in)
x230L-17GT	341 mm (13.42 in)	210 mm (8.27 in)	44 mm (1.73 in)	2.2 kg (4.85 lb)	3.6 kg (7.9 lb)	530 x 350 x 120 mm (20.87 x 13.78 x 4.72 in)
x230L-26GT	341 mm (13.42 in)	231 mm (9.09 in)	44 mm (1.73 in)	2.4 kg (5.3 lb)	4.0 kg (8.8 lb)	520 x 360 x 120 mm (20.47 x 14.17 x 4.72 in)

Power Characteristics

	No PoE Load			Full PoE+ Load			Max PoE Power	Max PoE Ports at 15W per Port	Max PoE+ Ports at 30W per Port
	Max Power Consumption	Max Heat Dissipation	Noise	Max Power Consumption	Max Heat Dissipation	Noise			
x230-10GP	16W	55 BTU/h	33 dBA	180W	126 BTU/h	41 dBA	124W	8	4
x230-10GT	16W	55 BTU/h	Fanless	-	-	-	-	-	-
x230-18GP	21W	72 BTU/h	34 dBA	330W	169 BTU/h	42 dBA	247W	16	8
x230-18GT	18W	61 BTU/h	29 dBA	-	-	-	-	-	-
x230-28GP	37W	127 BTU/h	34 dBA	520W	303 BTU/h	42 dBA	370W	24	12
x230-28GT	26W	89 BTU/h	34 dBA	-	-	-	-	-	-
x230L-17GT	15W	51 BTU/h	Fanless	-	-	-	-	-	-
x230L-26GT	20.5W	70 BTU/h	Fanless	-	-	-	-	-	-

Performance

- Up to 16K MAC addresses
- Up to 512 multicast entries
- 256MB DDR SDRAM (GP models)
- 512MB DDR SDRAM (GT models)
- 2048 configurable VLANs (GP models)
- 4094 configurable VLANs (GT models)
- 64MB flash memory
- Packet Buffer memory: 1.5MB
- Supports 10KB L2 jumbo frames
- Wirespeed forwarding

Reliability

- Modular AlliedWare Plus operating system
- Full environmental monitoring of PSU internal temperature and internal voltages. SNMP traps alert network managers in case of any failure

Flexibility and compatibility

- SFP ports will support any combination of 10/100/1000T, 100X, 100FX, 100BX, 1000X, 1000SX, 1000LX, 1000ZX or 1000ZX CWDM SFPs

Diagnostic tools

- Active Fiber Monitoring detects tampering on optical links
- Built-In Self Test (BIST)
- Find-me device locator
- Cable fault locator (TDR)
- Optical Digital Diagnostics Monitoring (DDM)
- Automatic link flap detection and port shutdown
- Ping polling for IPv4 and IPv6
- Port mirroring
- No limit on mirrored ports
- Up to 4 mirror (analyzer) ports for received traffic
- 1 mirror (analyzer) port for transmitted traffic
- VLAN mirroring (RSPAN)
- TraceRoute for IPv4 and IPv6

IP Features

- IPv4 static routing and RIP
- DHCPv4 relay and client
- DHCPv6 relay and client
- Device management over IPv6 networks with SNMPv6, Telnetv6, SSHv6 and Syslogv6
- NTPv6 client and server
- IPv6 Ready certified

Management

- Allied Telesis Autonomous Management Framework Plus (AMF Plus) enables powerful centralized management and zero-touch device installation and recovery
- Console management port on the front panel for ease of access
- NETCONF/RESTCONF northbound interface with YANG data modelling
- Eco-friendly mode allows ports and LEDs to be disabled to save power
- Web-based Graphical User Interface (GUI)
- Industry-standard CLI with context-sensitive help
- Powerful CLI scripting engine with built-in text editor
- SD/SDHC memory card socket allows software release files, configurations and other files to be stored for backup and distribution to other devices
- Configurable logs and triggers provide an audit trail of SD card insertion and removal

- Comprehensive SNMP MIB support for standards-based device management
- Management stacking allows up to 24 devices to be managed from a single console
- Event-based triggers allow user-defined scripts to be executed upon selected system events

Quality of Service (QoS)

- 8 priority queues with a hierarchy of high priority queues for real time traffic, and mixed scheduling, for each switch port
- Limit bandwidth per port or per traffic class down to 64kbps
- Wirespeed traffic classification with low latency essential for VoIP and real-time streaming media applications
- Policy-based QoS based on VLAN, port, MAC and general packet classifiers
- Policy-based storm protection
- Extensive remarking capabilities
- Taildrop for queue congestion control
- Strict priority, weighted round robin or mixed scheduling
- IP precedence and DiffServ marking based on layer 2, 3 and 4 headers

Resiliency Features

- Control Plane Prioritization (CPP) ensures the CPU always has sufficient bandwidth to process network control traffic
- Dynamic link failover (host attach)
- EPSRing (Ethernet Protection Switched Rings) with enhanced recovery for extra resiliency
- Loop protection: loop detection and thrash limiting
- PVST+ compatibility mode
- RRP snooping
- STP root guard

Security Features

- Access Control Lists (ACLs) based on layer 3 and 4 headers, per VLAN or port
- Configurable ACLs for management traffic
- Dynamic ACLs assigned via port authentication
- ACL Groups enable multiple hosts/ports to be included in a single ACL, reducing configuration
- Auth-fail and guest VLANs
- Authentication, Authorization and Accounting (AAA)
- Bootloader can be password protected for device security
- BPDU protection
- DHCP snooping, IP source guard and Dynamic ARP Inspection (DAI)
- DoS attack blocking and virus throttling
- Dynamic VLAN assignment
- MAC address filtering and MAC address lock-down
- Network Access and Control (NAC) features manage endpoint security
- Learn limits (intrusion detection) for single ports or LAGs
- Private VLANs provide security and port isolation for multiple customers using the same VLAN
- Secure Copy (SCP)
- Strong password security and encryption
- Tri-authentication: MAC-based, web-based and IEEE 802.1x
- RADIUS group selection per VLAN or port

Environmental specifications

- Operating temperature range:

- 0°C to 50°C (32°F to 122°F)
- 0°C to 40°C (32°F to 104°F) (x230L models)
- Derated by 1°C per 305 meters (1,000 ft)
- Storage temperature range: -20°C to 60°C (-4°F to 140°F)
- Operating relative humidity range: 0% to 90% non-condensing
- Storage relative humidity range: 0% to 95% non-condensing
- Operating altitude: 2,000 meters maximum (6,562 ft)

Electrical approvals and compliances

- EMC: EN55022 class A, FCC class A, VCCI class A
- Immunity: EN55024, EN61000-3-levels 2 (Harmonics), and 3 (Flicker) – AC models only

Safety

- Standards: UL60950-1, CAN/CSA-C22.2 No. 60950-1-03, EN60950-1, EN60825-1, AS/NZS 60950.1
- Certifications: UL, cUL, UL-IEU

Restrictions on Hazardous Substances (RoHS) Compliance

- EU RoHS compliant
- China RoHS compliant

STANDARDS & PROTOCOLS

AlliedWare Plus Operating System

Version 5.5.5-2

Cryptographic Algorithms

FIPS Approved Algorithms

Encryption (Block Ciphers):

AES (ECB, CBC, CFB and OFB Modes)
3DES (ECB, CBC, CFB and OFB Modes)

Block Cipher Modes:

CCM
CMAC
GCM
XTS

Digital Signatures & Asymmetric Key Generation:

DSA
ECDSA
RSA
Secure Hashing:
SHA-1
SHA-2 (SHA-224, SHA-256, SHA-384, SHA-512)

Message Authentication:

HMAC (SHA-1, SHA-2(224, 256, 384, 512)

Random Number Generation:

DRBG (Hash, HMAC and Counter)

Non FIPS Approved Algorithms

RNG (AES128/192/256)

DES

MD5

Ethernet

IEEE 802.2 Logical Link Control (LLC)

IEEE 802.3 Ethernet

IEEE 802.3ab1000BASE-T

IEEE 802.3af Power over Ethernet (PoE)

IEEE 802.3at Power over Ethernet plus (PoE+)

IEEE 802.3az Energy Efficient Ethernet (EEE)

IEEE 802.3u 100BASE-X

IEEE 802.3x Flow control - full-duplex operation

IEEE 802.3z 1000BASE-X

IEEE 1588v2 Precision clock synchronization protocol v2

IPv4 Features

RFC 768	User Datagram Protocol (UDP)
RFC 791	Internet Protocol (IP)
RFC 792	Internet Control Message Protocol (ICMP)
RFC 793	Transmission Control Protocol (TCP)
RFC 826	Address Resolution Protocol (ARP)
RFC 894	Standard for the transmission of IP datagrams over Ethernet networks
RFC 919	Broadcasting Internet datagrams
RFC 922	Broadcasting Internet datagrams in the presence of subnets
RFC 932	Subnetwork addressing scheme
RFC 950	Internet standard subnetting procedure
RFC 1042	Standard for the transmission of IP datagrams over IEEE 802 networks
RFC 1071	Computing the Internet checksum
RFC 1122	Internet host requirements
RFC 1191	Path MTU discovery
RFC 1518	An architecture for IP address allocation with CIDR
RFC 1519	Classless Inter-Domain Routing (CIDR)
RFC 1812	Requirements for IPv4 routers
RFC 1918	IP addressing
RFC 2581	TCP congestion control

IPv6 Features

RFC 1981	Path MTU discovery for IPv6
RFC 2460	IPv6 specification
RFC 2464	Transmission of IPv6 packets over Ethernet networks
RFC 2711	IPv6 router alert option
RFC 3484	Default address selection for IPv6
RFC 3587	IPv6 global unicast address format
RFC 3596	DNS extensions to support IPv6
RFC 4007	IPv6 scoped address architecture
RFC 4193	Unique local IPv6 unicast addresses
RFC 4213	Transition mechanisms for IPv6 hosts and routers
RFC 4291	IPv6 addressing architecture
RFC 4443	Internet Control Message Protocol (ICMPv6)
RFC 4861	Neighbor discovery for IPv6
RFC 4862	IPv6 Stateless Address Auto-Configuration (SLAAC)
RFC 5014	IPv6 socket API for source address selection
RFC 5095	Deprecation of type 0 routing headers in IPv6
RFC 5175	IPv6 Router Advertisement (RA) flags option
RFC 6105	IPv6 Router Advertisement (RA) guard

Management

AT Enterprise MIB including AMF Plus MIB and SNMP traps	
Optical DDM MIB	
SNMPv1, v2c and v3	
IEEE 802.1AB Link Layer Discovery Protocol (LLDP)	
RFC 1155	Structure and identification of management information for TCP/IP-based Internets
RFC 1157	Simple Network Management Protocol (SNMP)
RFC 1212	Concise MIB definitions
RFC 1213	MIB for network management of TCP/IP-based Internets: MIB-II
RFC 1215	Convention for defining traps for use with the SNMP
RFC 1227	SNMP MUX protocol and MIB
RFC 1239	Standard MIB
RFC 1724	RIPv2 MIB extension
RFC 2578	Structure of Management Information v2 (SMIv2)
RFC 2579	Textual conventions for SMIv2
RFC 2580	Conformance statements for SMIv2
RFC 2674	Definitions of managed objects for bridges with traffic classes, multicast filtering and VLAN extensions
RFC 2741	Agent extensibility (AgentX) protocol
RFC 2819	RMON MIB (groups 1,2,3 and 9)
RFC 2863	Interfaces group MIB
RFC 3176	sFlow: a method for monitoring traffic in switched and routed networks
RFC 3411	An architecture for describing SNMP management frameworks
RFC 3412	Message processing and dispatching for the SNMP
RFC 3413	SNMP applications
RFC 3414	User-based Security Model (USM) for SNMPv3

RFC 3415	View-based Access Control Model (VACM) for SNMP
RFC 3416	Version 2 of the protocol operations for the SNMP
RFC 3417	Transport mappings for the SNMP
RFC 3418	MIB for SNMP
RFC 3621	Power over Ethernet (PoE) MIB
RFC 3635	Definitions of managed objects for the Ethernet-like interface types
RFC 3636	IEEE 802.3 MAU MIB
RFC 4022	MIB for the Transmission Control Protocol (TCP)
RFC 4113	MIB for the User Datagram Protocol (UDP)
RFC 4188	Definitions of managed objects for bridges
RFC 4292	IP forwarding table MIB
RFC 4293	MIB for the Internet Protocol (IP)
RFC 4318	Definitions of managed objects for bridges with RSTP
RFC 4560	Definitions of managed objects for remote ping, traceroute and lookup operations
RFC 5424	Syslog protocol

Multicast support

IGMP query solicitation	
IGMP snooping (IGMPv1, v2 and v3)	
IGMP snooping fast-leave	
MLD snooping (MLDv1 and v2)	
RFC 1112	Host extensions for IP multicasting (IGMPv1)
RFC 2236	Internet Group Management Protocol v2 (IGMPv2)
RFC 2715	Interoperability rules for multicast routing protocols
RFC 3306	Unicast-prefix-based IPv6 multicast addresses
RFC 3376	IGMPv3
RFC 4541	IGMP and MLD snooping switches

Quality of Service (QoS)

IEEE 802.1p Priority tagging	
RFC 2211	Specification of the controlled-load network element service
RFC 2474	DiffServ precedence for eight queues/port
RFC 2475	DiffServ architecture
RFC 2597	DiffServ Assured Forwarding (AF)
RFC 2697	A single-rate three-color marker
RFC 2698	A two-rate three-color marker
RFC 3246	DiffServ Expedited Forwarding (EF)

Resiliency Features

IEEE 802.1AX Link aggregation (static and LACP)	
IEEE 802.1D MAC bridges	
IEEE 802.1s Multiple Spanning Tree Protocol (MSTP)	
IEEE 802.1w Rapid Spanning Tree Protocol (RSTP)	
IEEE 802.3adStatic and dynamic link aggregation	

Routing Information Protocol (RIP)

RFC 1058	Routing Information Protocol (RIP)
RFC 2080	RIPng for IPv6
RFC 2081	RIPng protocol applicability statement
RFC 2082	RIP-2 MD5 authentication
RFC 2453	RIPv2

Security Features

SSH remote login	
SSLv2 and SSLv3	
TACACS+ Accounting, Authentication and Authorisation (AAA)	
IEEE 802.1X	Authentication protocols (TLS, TTLS, PEAP and MD5)
IEEE 802.1X	Multi-suplicant authentication
IEEE 802.1X	Port-based network access control
RFC 2560	X.509 Online Certificate Status Protocol (OCSP)
RFC 2818	HTTP over TLS ("HTTPS")
RFC 2865	RADIUS authentication
RFC 2866	RADIUS accounting
RFC 2868	RADIUS attributes for tunnel protocol support
RFC 2986	PKCS #10: certification request syntax specification v1.7
RFC 3546	Transport Layer Security (TLS) extensions

RFC 3579	RADIUS support for Extensible Authentication Protocol (EAP)
RFC 3580	IEEE 802.1x RADIUS usage guidelines
RFC 3748	PPP Extensible Authentication Protocol (EAP)
RFC 4251	Secure Shell (SSHv2) protocol architecture
RFC 4252	Secure Shell (SSHv2) authentication protocol
RFC 4253	Secure Shell (SSHv2) transport layer protocol
RFC 4254	Secure Shell (SSHv2) connection protocol
RFC 5176	RADIUS CoA (Change of Authorization)
RFC 5280	X.509 certificate and Certificate Revocation List (CRL) profile
RFC 5425	Transport Layer Security (TLS) transport mapping for Syslog
RFC 5656	Elliptic curve algorithm integration for SSH
RFC 6125	Domain-based application service identity within PKI using X.509 certificates with TLS
RFC 6614	Transport Layer Security (TLS) encryption for RADIUS
RFC 6668	SHA-2 data integrity verification for SSH
RFC 8446	Transport Layer Security (TLS) v1.3

Services

RFC 854	Telnet protocol specification
RFC 855	Telnet option specifications
RFC 857	Telnet echo option
RFC 858	Telnet suppress go ahead option
RFC 1091	Telnet terminal-type option
RFC 1350	Trivial File Transfer Protocol (TFTP)
RFC 1985	SMTP service extension
RFC 2049	MIME
RFC 2131	DHCPv4 relay and client
RFC 2616	Hypertext Transfer Protocol - HTTP/1.1
RFC 2821	Simple Mail Transfer Protocol (SMTP)
RFC 2822	Internet message format
RFC 3046	DHCP relay agent information option (DHCP option 82)
RFC 3315	DHCPv6 relay and client
RFC 3993	Subscriber-ID suboption for DHCP relay agent option
RFC 4330	Simple Network Time Protocol (SNTP) version 4
RFC 5905	Network Time Protocol (NTP) version 4

VLAN support

IEEE 802.1ad Provider bridges (VLAN stacking, Q-in-Q)	
IEEE 802.1Q Virtual LAN (VLAN) bridges	
IEEE 802.1v VLAN classification by protocol and port	
IEEE 802.3acVLAN tagging	

Voice over IP

LLDP-MED	ANSI/TIA-1057
Voice VLAN	

FEATURE LICENSES

	Description	Includes
AT-FL-x230-QinQ	VLAN double tagging (Q-in-Q) license	■ VLAN Q-in-Q
AT-FL-x230-OF13-1YR	OpenFlow license for 1 year	■ OpenFlow v1.3
AT-FL-x230-OF13-5YR	OpenFlow license for 5 years	■ OpenFlow v1.3
AT-FL-x230-UDLD	UniDirectional Link Detection	■ UDLD
AT-FL-x230-PTP	PTP (IEEE 1588v2) license	■ PTP Transparent Mode
AT-FL-x230-8032	ITU-T G.8032 license	■ G.8032 ring protection ■ Ethernet CFM

ORDERING INFORMATION

Model availability can vary between regions. Please check to see which models are available in your region.

AT-x230-10GP-xx¹	L3 switch with 8 x 10/100/1000T PoE ports and 2 x 100/1000X SFP ports
AT-x230-10GT-xx	L3 switch with 8 x 10/100/1000T ports and 2 x 100/1000X SFP ports
AT-x230-18GP-xx¹	L3 switch with 16 x 10/100/1000T PoE ports and 2 x 100/1000X SFP ports
AT-x230-18GT-xx	L3 switch with 16 x 10/100/1000T ports and 2 x 100/1000X SFP ports
AT-x230-28GP-xx¹	L3 switch with 24 x 10/100/1000T PoE ports and 4 x 100/1000X SFP ports
AT-x230-28GT-xx	L3 switch with 24 x 10/100/1000T ports and 4 x 100/1000X SFP ports
AT-x230L-17GT-xx	L3 switch with 16 x 10/100/1000T ports and 1 x 100/1000X SFP port
AT-x230L-26GT-xx	L3 switch with 24 x 10/100/1000T ports and 2 x 100/1000X SFP ports
AT-RKMT-J05	Rack mount kit for x230-10GT
AT-RKMT-J13	Rack mount kit for x230-18GP/18GT, x230L-17GT
AT-RKMT-J14	Rack mount kit for x230-10GP
AT-STND-J03	Stand-kit for AT-x230L-17/26GT, AT-x230-18/28GT, and AT-x230-10/18GP

Where xx =
 10 for US power cord
 20 for no power cord
 30 for UK power cord
 40 for AU power cord
 50 for EU power cord

¹ Trade Act Agreement compliant (TAA)

Accessories

1000Mbps SFP Modules	
AT-SPTXc	1000T 100 m copper
AT-SPSX	1000SX GbE multi-mode 850 nm fiber up to 550 m
AT-SPSX/I	1000SX GbE multi-mode 850 nm fiber up to 550 m industrial temperature
AT-SPEX	1000X GbE multi-mode 1310 nm fiber up to 2 km
AT-SPLX10a	1000LX GbE single-mode 1310 nm fiber up to 10 km
AT-SPLX10a/I	1000LX GbE single-mode 1310 nm fiber up to 10 km industrial temperature
AT-SPBD10-13	1000LX GbE Bi-Di (1310 nm Tx, 1490 nm Rx) fiber up to 10 km
AT-SPBD10-14	1000LX GbE Bi-Di (1490 nm Tx, 1310 nm Rx) fiber up to 10 km
AT-SPBD20-13/I	1000BX GbE Bi-Di (1310 nm Tx, 1490 nm Rx) fiber up to 20 km industrial temperature
AT-SPBD20-14/I	1000BX GbE Bi-Di (1490 nm Tx, 1310 nm Rx) fiber up to 20 km industrial temperature
AT-SPBD40-13/I	1000LX GbE single-mode Bi-Di (1310 nm Tx, 1490 nm Rx) fiber up to 40 km, industrial temperature
AT-SPBD40-14/I	1000LX GbE single-mode Bi-Di (1490 nm Tx, 1310 nm Rx) fiber up to 40 km, industrial temperature

100Mbps SFP Modules	
AT-SPFX/2	100FX multi-mode 1310 nm fiber up to 2 km
AT-SPFX30/I-90	100FX LC single-mode 1310 nm fiber up to 30 km, I-Temp
AT-SPFXBD-LC-13	100BX Bi-Di (1310 nm Tx, 1550 nm Rx) fiber up to 10 km
AT-SPFXBD-LC-15	100BX Bi-Di (1550 nm Tx, 1310 nm Rx) fiber up to 10 km