

x240 Series

Multi-Gigabit Stackable Edge Switches



Overview

Allied Telesis x240 Series Layer 3 multi-gigabit switches offer an impressive set of features in a compact design, making them ideal for high-speed connectivity at the edge of the network. They support 10M/100M/1/2.5/5G connectivity for both legacy and high-speed devices with maximum throughput, and enable an easy performance upgrade using existing Cat5e building cables.

Power over Ethernet (PoE++) models connect and power wireless access points, IP video surveillance cameras, and more with up to 90W per port. With 8, 24 or 48 multi-gigabit ports and 10 gigabit SFP+ uplinks, the x240 series enables flexible deployment and secure access at the network edge.

The x240 Series can form a virtual chassis stack (VStack™) allowing 2 units to be managed as a single virtual device for simplicity and resiliency.

High-speed wireless

The x240 Series provide support for both 2.5 and 5 Gigabit connectivity, allowing high-speed wireless to run at full capacity while avoiding the need to upgrade existing Cat5e/Cat6 cables.

Secure

Network Access Control (NAC) gives unprecedented control over user access to mitigate threats to network infrastructure.

Allied Telesis x240 switches use 802.1x port-based authentication, in partnership with standards-compliant dynamic VLAN assignment, to assess a user's adherence to network security policies and either grant access or offer remediation. Tri-authentication ensures the network is only accessed by known users and devices. Secure access is also available for guests.

Security from malicious network attacks is provided by a comprehensive range of features such as DHCP snooping, STP root guard, BPDU protection and access control lists. Each of these can be configured to perform a variety of actions upon detection of a suspected attack.

Network protection

Advanced storm protection features include bandwidth limiting, policy-based storm protection and packet storm protection.

Network storms are often caused by cabling errors that result in a network loop. Allied Telesis x240 Series switches provide features to detect loops as soon as they are created. Loop detection and thrash limiting take immediate action to prevent network storms.

Manageable

The x240 runs the advanced AlliedWare Plus™ fully featured operating system, delivering a rich feature set and an industry-standard Command Line Interface (CLI). This reduces training requirements and is consistent across all AlliedWare Plus devices, simplifying network management.

The web-based Device GUI is an easy-to-use and powerful management tool, with comprehensive monitoring facilities.

Powerful network management

Meeting the increased management requirements of modern converged networks, Allied Telesis Autonomous Management Framework™ Plus (AMF Plus) automates many everyday tasks including configuration management. The complete network can be managed as a single virtual device with powerful centralized management features. Growing the network can be accomplished with plug-and-play simplicity, and network node recovery is fully zero-touch.



Key Features

- Autonomous Management Framework™ Plus (AMF Plus)
- AMF-Security compatible
- 10M/100M/1/2.5/5G multi-gigabit ports
- 10 Gigabit uplinks
- Up to 90W PoE++ power per port
- VStack 2 units at any speed
- EPSR™ and G.8032 ERPS for resilient ring-based topologies
- Active Fiber Monitoring (AFM)
- Precision Time Protocol (PTP) Transparent mode
- Enhanced Transmission Selection (ETS)
- Link Monitoring
- Flexible ACLs
- Loop and storm protection
- Upstream Forwarding Only (UFO)
- OpenFlow for SDN
- NETCONF/RESTCONF with YANG data modelling

AMF Plus secure mode increases network security with management traffic encryption, authorization, and monitoring.

Future-proof

x240 Series switches are Software Defined Networking (SDN) ready and able to support OpenFlow v1.3.

Easy network upgrade

Increasing network performance from existing 1 gigabit Allied Telesis edge switches to x240 multi-gigabit switches is easy. AMF Plus auto-recovery enables a plug-and-play upgrade, as the x240 switches are auto-configured to match the previous devices.

KEY FEATURES

Autonomous Management Framework™ Plus (AMF Plus)

AMF Plus is a sophisticated suite of management tools that provide a simplified approach to network management. Common tasks are automated or made so simple that the every-day running of a network can be achieved without the need for highly-trained, and expensive, network engineers. Powerful features like centralized management, auto-backup, auto-upgrade, auto-provisioning and auto-recovery enable plug-and-play networking and zero-touch management.

An AMF Plus license operating in the network provides all standard AMF network management and automation features, and also enables the AMF Plus intentbased networking features in Vista Manager EX (from version 3.10.1 onwards)

Multi-gigabit performance

The x240 Series connects at five speeds (10M/100M/1/2.5/5G), supporting anything from legacy devices to the latest high-speed wireless APs with maximum performance. When partnered with 10 gigabit uplink ports, any bottlenecks at the edge of the network are removed.

Power over Ethernet Plus (PoE++)

With PoE, a separate power connection to media endpoints such as IP phones and wireless access points is not necessary. PoE reduces costs.

The x240 PoE models support up to 90W per port (PoE++) to connect high power devices such as high resolution PTZ cameras, enhanced infrared lighting and lighting controllers, remote Point of Sale (POS) kiosks, and more.

Virtual Chassis Stacking (VCStack™)

Create a VCStack of two units with 40Gbps stacking bandwidth, and dual links for increased resiliency. VCStack provides high availability with network resources spread across stacked units, reducing the impact if a unit fails. Aggregating switch ports on different units across the stack provides excellent network resiliency.

Ethernet Protection Switched Ring (EPSRing™)

EPSRing allows several x240 switches to join a protected ring capable of recovery within as little as 50ms. This feature is perfect for high availability in enterprise networks.

G.8032 Ethernet Ring Protection

G.8032 provides standards-based high-speed ring protection, that can be deployed stand-alone, or interoperate with Allied Telesis EPSR.

Ethernet Connectivity Fault Monitoring (CFM) proactively monitors links and VLANs, and provides alerts when a fault is detected.

Access Control Lists (ACLs)

ACLs filter network traffic to control whether routed packets are forwarded or blocked, and can be applied to a specific port or a VLAN. This provides a powerful network security mechanism to select the types of traffic to be analyzed, forwarded, or influenced in some way.

Easy To Manage

The AlliedWare Plus operating system incorporates an industry standard CLI, facilitating intuitive manageability.

With three distinct modes, the CLI is very secure, and the use of SSHv2 encrypted and strongly authenticated remote login sessions ensures CLI access is not compromised.

NETCONF/RESTCONF

NETCONF/RESTCONF with YANG data modeling provides a standardized way to represent data and securely configure devices.

Storm protection

Advanced packet storm control features protect the network from broadcast storms:

Bandwidth limiting minimizes the effects of the storm by reducing the amount of flooding traffic.

Policy-based storm protection is more powerful than bandwidth limiting, restricting damage and providing the ability to define the traffic rate that creates a broadcast storm. The action the device should take when it detects a storm can be configured, such as disabling the port from the VLAN or shutting the port down.

Loop protection

Thrash limiting, also known as Rapid MAC movement, detects and resolves network loops. It is highly user-configurable — from the rate of looping traffic to the type of action the switch should take when it detects a loop.

With thrash limiting, the switch only detects a loop when a storm has occurred, which can potentially cause disruption to the network. To avoid this, loop detection works in conjunction with thrash limiting to send special packets, called Loop Detection Frames (LDF), that the switch listens for. If a port receives an LDF packet, one can choose to disable the port, disable the link, or send an SNMP trap.

Spanning Tree Protocol (STP) Root Guard

STP root guard designates which devices can assume the root bridge role in an STP network. This stops an undesirable device from taking over this role, where it could either compromise network performance or cause a security weakness.

Bridge Protocol Data Unit (BPDU) protection

BPDU protection adds extra security to STP. It protects the spanning tree configuration by preventing malicious DoS attacks caused by spoofed BPDUs. If a BPDU packet is received on a protected port, the BPDU protection feature disables the port and alerts the network manager.

sFlow

sFlow monitors networks to provide visibility for performance optimization, usage accounting/billing, and defense against security threats. Sampled packets sent to a collector provide a real-time view of network traffic.

Tri-authentication

As well as 802.1x port-based authentication, web authentication enables guest access and MAC authentication supports end points that do not have an 802.1x supplicant. All three authentication methods—802.1x, MAC-based and Web-based—can be enabled simultaneously on the same port, resulting in tri-authentication.

TACACS+ Command Authorization

TACACS+ Command Authorization offers centralized control over which commands may be issued by each

specific AlliedWare Plus device user. It complements authentication and accounting services for an AAA solution.

UniDirectional Link Detection

UDLD monitors fiber-optic links between switches, and prevents traffic being sent across a bad link by blocking the ports at both ends of the link in the event that either the transmitter or receiver for that connection fails.

Optical DDM

Most SFP/SFP+/QSFP transceivers support Digital Diagnostics Monitoring (DDM) of parameters such as optical output power, temperature, laser bias, etc. This simplifies diagnosing fiber connection problems.

Active Fiber Monitoring

AFM prevents eavesdropping on fiber data or stacking links by monitoring received optical power. If an intrusion is detected, the link can be automatically shut down, or an alert sent.

VLAN Mirroring (RSPAN)

VLAN mirroring allows traffic from a port on a remote switch to be analyzed locally. Traffic being transmitted or received on the port is duplicated and sent across the network on a special VLAN.

Find Me

The "Find Me" feature is a visual way to identify the desired physical switch in a busy server room for maintenance or other purposes, by causing its LEDs to flash in a specified pattern.

Precision Time Protocol (PTP)

PTP (IEEE 1588v2) synchronizes clocks throughout the network with micro-second accuracy, supporting industrial automation and control systems.

Link Monitoring (Linkmon)

Linkmon health monitoring regularly sends probes over key links to gather metrics comprising latency, jitter, and probe loss. This supports pro-active management, and can be used with triggers to automate a change to network configuration in response to the declining health of a monitored link.

Upstream Forwarding Only (UFO)

UFO lets you manage which ports in a VLAN can communicate with each other, and which only have upstream access to services, for secure multi-user deployment.

VLAN Translation

VLAN Translation allows traffic arriving on a VLAN to be mapped to a different VLAN on the outgoing interface.

Service Providers can provide customers with a unique VLAN ID, which can be changed for data transfer through the SP's network.

In the Enterprise, it can be used to merge two networks together, without manually reconfiguring the VLAN numbering scheme.

Quality of Service

Enhanced Transmission Selection (ETS) provides quality of service by allocating bandwidth to important traffic classes, with the flexibility to share remaining bandwidth to maximize traffic throughput and performance.

KEY SOLUTIONS

High performance at the network edge

The convergence of network services in the Enterprise has led to increasing demand for highly available networks with minimal downtime. The diagram shows x240 switches with high performance EPSR ring connectivity to the x530 VCStack core. This topology provides ring recovery in as little as 50ms if required, ensuring essential services and online business applications are always available.

Multi-gigabit connectivity provides a high-value solution with up to 5 x the performance of traditional 1 gigabit networks. Multi-gigabit PC connections and switch uplinks can maximize the use of existing Cat5e building backbone cables.

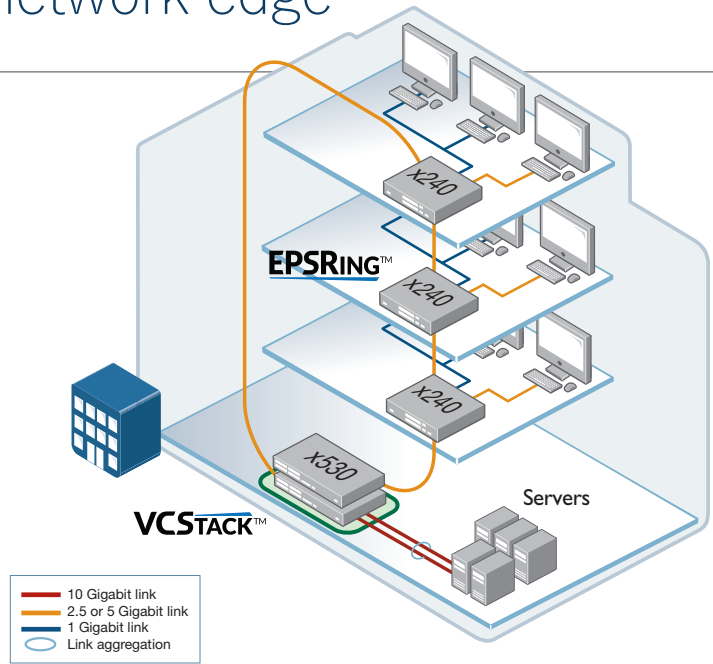

Resilient connectivity and easy management

The Power over Ethernet x240 models supply up to 90W (PoE++) per port to connect and power devices such as 4K PTZ security cameras. Using VCStack enables two x240 units to create resilient 2.5/5G multi-gigabit connectivity to high-speed APs. This removes bottlenecks and maximizes performance for the many wireless devices used today.

AMF Plus provides an easy yet powerful solution for centralized administration and network automation. All x240 switches are automatically backed-up to the AMF Plus master, so device replacement is fully zero-touch and carried out with plug-and-play simplicity.

Vista Manager is Allied Telesis powerful monitoring and management platform providing easy visual network administration, the ability to configure multiple devices at once, and actionable reporting for proactive management. Vista Manager and AMF Plus combine to reduce the time and cost of network management.

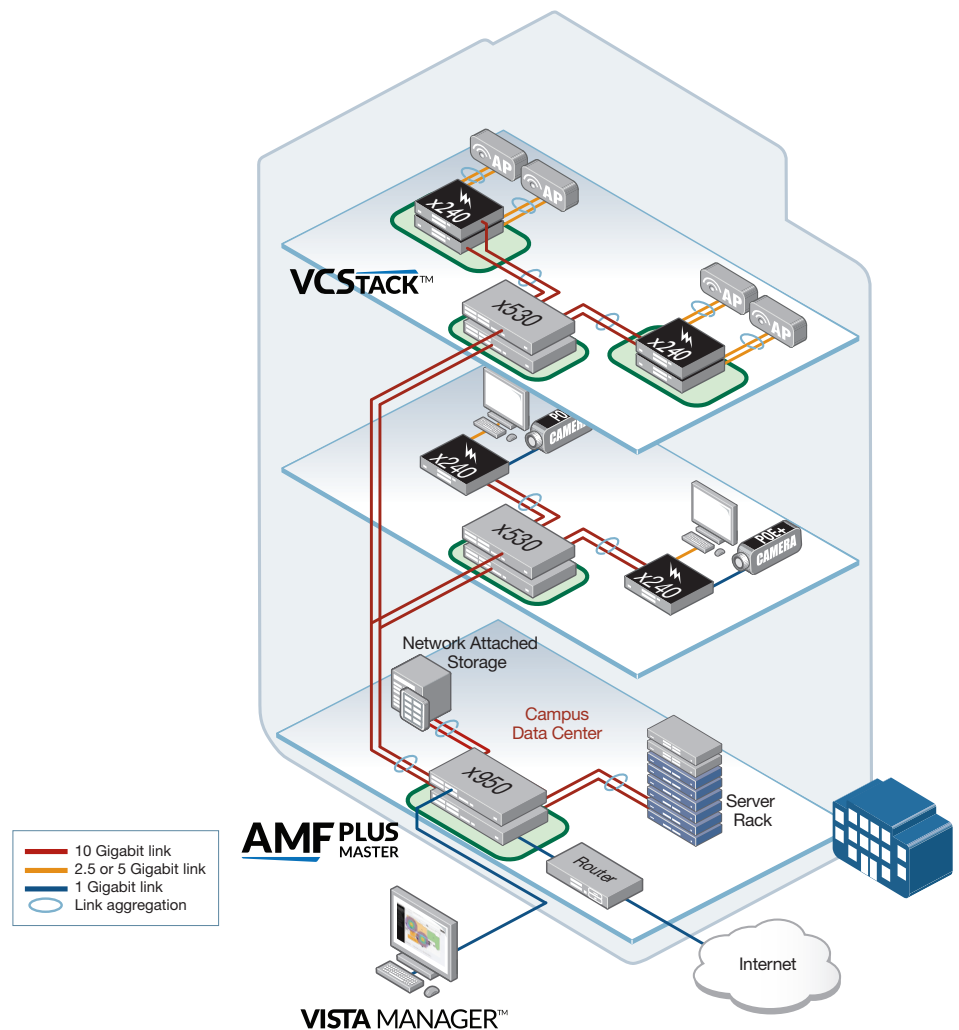

SPECIFICATIONS

Product Specifications

	10M/100M/1/2.5/5 Gigabit Ports	1/10 Gigabit SFP+ Ports	Total Ports	PoE Enable Ports	Switching Fabric	Forwarding Rate
x240-10GHXm	8	2	10	8	120Gbps	89.3Mpps
x240-10GTXm	8	2	10	-	120Gbps	89.3Mpps
x240-26GHXm	24	2	26	24	280Gbps	208.3Mpps
x240-26GTXm¹	24	2	26	-	280Gbps	208.3Mpps
x240-52GHXm¹	48	4	52	48	560Gbps	416.6Mpps
x240-52GTXm¹	48	4	52	-	560Gbps	416.6Mpps

Power Characteristics

	No PoE Load			Full PoE+ Load			Max PoE Power	PoE sourcing ports					
	Max Power Consumption	Max Heat Dissipation	Noise	Max Power Consumption	Max Heat Dissipation	Noise		PoE (7.5W)	PoE (15.4W)	PoE+ (30W)	PoE++ (45W)	PoE++ (60W)	PoE++ (90W)
x240-10GHXm	44W	150 BTU/h	32-39 db	340W	1200 BTU/h	39-55 db	240W	8	8	8	5	4	2
x240-10GTXm	38W	130 BTU/h	32-39 db	-	-	-	-	-	-	-	-	-	-
x240-26GHXm	86W	290 BTU/h	38-52 db	540W	1900 BTU/h	41-58 db	370W	24	24	12	8	6	4
x240-26GTXm¹	83W	280 BTU/h	38-45 db	-	-	-	-	-	-	-	-	-	-
x240-52GHXm¹	TBD	TBD	TBD	TBD	TBD	TBD	740W	48	48	24	16	12	8
x240-52GTXm¹	TBD	TBD	TBD	TBD	TBD	-	-	-	-	-	-	-	-

Physical Specifications

	Width	Depth	Height	Weight	Packaged Dimensions	Weight
x240-10GHXm	210 mm (8.27 in)	346 mm (13.62 in)	42.5 mm (1.67 in)	2.7 kg (5.9 lb)	461 x 371 x 153 mm (18.15 x 14.60 x 6.02 in)	3.8 kg (8.3 lb)
x240-10GTXm	210 mm (8.27 in)	275 mm (10.83 in)	42.5 mm (1.67 in)	1.9 kg (4.2 lb)	433 x 257 x 102 mm (17.44 x 10.12 x 4.01 in)	2.6 kg (5.7 lb)
x240-26GHXm	440 mm (17.32 in)	290 mm (11.41 in)	44 mm (1.73 in)	4.3 kg (9.4 lb)	547 x 364 x 115 mm (21.53 x 14.33 x 4.53 in)	5.6 kg (12.3 lb)
x240-26GTXm¹	440 mm (17.32 in)	290 mm (11.41 in)	44 mm (1.73 in)	3.7 kg (8.1 lb)	547 x 364 x 115 mm (21.53 x 14.33 x 4.53 in)	5.0 kg (11.0 lb)
x240-52GHXm¹	441 mm (17.36 in)	421 mm (16.57 in)	44 mm (1.73 in)	TBD	TBD	TBD
x240-52GTXm¹	441 mm (17.36 in)	421 mm (16.57 in)	44 mm (1.73 in)	TBD	TBD	TBD

Latency (microseconds)

	Port Speed			
	1Gbps	2.5Gbps	5Gbps	10Gbps
x240-10GHXm	5.6µs	8.7µs	6.1µs	2.9µs
x240-10GTXm	4.5µs	8.7µs	5.9µs	2.9µs
x240-26GHXm	4.5µs	8.6µs	6.0µs	3.0µs
x240-26GTXm¹	4.4µs	8.6µs	5.9µs	2.9µs
x240-52GHXm¹	TBD	TBD	TBD	TBD
x240-52GTXm¹	TBD	TBD	TBD	TBD

Performance

- Up to 32K MAC addresses
- Up to 100 multicast entries
- 1GB DDR4 SDRAM
- 4094 configurable VLANs
- 256MB flash memory
- Packet Buffer memory: 3MB
- Supports 9KB L2 jumbo frames
- Wire-speed forwarding

Reliability

- Modular AlliedWare Plus operating system

¹ Models available in the future

- Full environmental monitoring of PSU internal temperature and internal voltages. SNMP traps alert network managers in case of any failure

Flexibility and compatibility

- 10G SFP+ ports will support any combination of Allied Telesis 1000Mbps SFP and 10GbE SFP+ modules and direct attach cables listed in this document under Ordering Information
- Port speed can be set manually or by auto-negotiation

Diagnostic tools

- Active Fiber Monitoring detects tampering on optical links
- Built-In Self Test (BIST)
- Find-me device locator
- Cable fault locator (TDR)
- Connectivity Fault Management (CFM) for use with G.8032 ERPS
- Link Monitoring
- Optical Digital Diagnostics Monitoring (DDM)
- Automatic link flap detection and port shutdown
- Ping polling for IPv4 and IPv6
- Port mirroring
 - No limit on mirrored ports
 - Up to 7 mirror (analyzer) ports
- VLAN mirroring (RSPAN)
- Uni-Directional Link Detection (UDLD)
- TraceRoute for IPv4 and IPv6

IP Features

- IPv4 static routing and RIP
- IPv4 and IPv6 dual stack
- Device management over IPv6 networks with SNMPv6, Telnetv6, SSHv6 and Syslogv6
- DHCP client and relay for IPv4
- DHCP client for IPv6

Management

- Allied Telesis Autonomous Management Framework Plus (AMF Plus) enables powerful centralized management and zero-touch device installation and recovery
- Console management port on the front panel for ease of access
- NETCONF/RESTCONF northbound interface with YANG data modelling
- Eco-friendly mode allows ports and LEDs to be disabled to save power
- Web-based Graphical User Interface (GUI)
- Industry-standard CLI with context-sensitive help
- Powerful CLI scripting engine with built-in text editor
- A USB socket allows software releases, configuration, and other files to be stored for backup and distribution to other devices
- Comprehensive SNMP MIB support for standards-based device management
- Management stacking allows up to 24 devices to be managed from a single console
- Voice VLAN
- Event-based triggers allow user-defined scripts to be executed upon selected system events

Quality of Service (QoS)

- 8 priority queues with a hierarchy of high priority queues for real time traffic, and mixed scheduling, for each switch port
- Limit bandwidth per port or per traffic class down to 64kbps

- Wirespeed traffic classification with low latency essential for VoIP and real-time streaming media applications
- Policy-based QoS based on VLAN, port, MAC and general packet classifiers
- Policy-based storm protection
- Extensive remarking capabilities
- Taildrop for queue congestion control
- Strict priority, weighted round robin or mixed scheduling
- IP precedence and DiffServ marking based on layer 2, 3 and 4 headers
- Enhanced Transmission Selection (ETS)

Resiliency Features

- Control Plane Prioritization (CPP) ensures the CPU always has sufficient bandwidth to process network control traffic
- Dynamic link failover (host attach)
- EPSRing (Ethernet Protection Switched Rings) with enhanced recovery for extra resiliency
- Flexi-stacking - use any port-speed to stack
- Long-distance stacking with 10G SFP+ modules (LD-VCStack)
- VCStack fast failover minimizes network disruption
- Loop protection: loop detection and thrash limiting
- PVST+ compatibility mode
- Ethernet Ring Protection Switching (ITU-T G.8032 ERPS)
- Continuous Power over Ethernet (CPOE)
- RRP snooping
- STP root guard

Security Features

- Access Control Lists (ACLs) based on layer 3 and 4 headers, per VLAN or port
- Configurable ACLs for management traffic
- Dynamic ACLs assigned via port authentication
- ACL Groups enable multiple hosts/ports to be included in a single ACL, reducing configuration
- Auth-fail and guest VLANs
- RADIUS and TACACS+ Authentication, Authorization and Accounting (AAA)
- Bootloader can be password protected for device security
- BPDU protection
- DHCP snooping, IP source guard and Dynamic ARP Inspection (DAI)
- DoS attack blocking and virus throttling
- Local RADIUS server for user and device authentication
- Dynamic VLAN assignment
- MAC address filtering and MAC address lock-down
- Network Access and Control (NAC) features manage endpoint security
- Learn limits (intrusion detection) for single ports or LAGs
- Secure Copy (SCP)
- Strong password security and encryption
- Tri-authentication: MAC-based, web-based and IEEE 802.1x
- Secure File Transfer Protocol (SFTP) client
- Simple Certificate Enrollment Protocol (SCEP) supports secure management
- Local RADIUS server for user and device authentication
- RADIUS group selection per VLAN or port
- SFTP client

VLAN Support

- Voice VLAN
- Private VLANs provide security and port isolation for multiple customers using the same VLAN
- VLAN ID translation

Environmental specifications

- Operating temperature range:
 - 0°C to 50°C (32°F to 122°F)
 - Derated by 1°C per 305 meters (1,000 ft)
- Storage temperature range:
 - 25°C to 70°C (-13°F to 158°F)
- Operating relative humidity range:
 - 5% to 90% non-condensing
- Storage relative humidity range:
 - 5% to 95% non-condensing
- Operating altitude:
 - 2,000 meters maximum (6,562 ft)

Electrical Approvals and Compliances

- EMC: EN55032 class A, FCC class A, VCCI class A, ICES-003 class A
- Immunity: EN55035, EN61000-3-levels 2 (Harmonics), and 3 (Flicker) – AC models only

Safety

- Standards: UL62368-1, CAN/CSA-C22.2 No.62368-1, EN62368-1, EN60825-1, AS/NZS62368.1
- Certification: UL, cUL

Restrictions on Hazardous Substances (RoHS) Compliance

- EU RoHS compliant
- China RoHS compliant

STANDARDS & PROTOCOLS

AlliedWare Plus Operating System

Version 5.5.6

Cryptographic Algorithms

FIPS Approved Algorithms
Encryption (Block Ciphers):
 AES (ECB, CBC, CFB and OFB Modes)
 3DES (ECB, CBC, CFB and OFB Modes)
Block Cipher Modes:

CCM
 CMAC
 GCM
 XTS

Digital Signatures & Asymmetric Key Generation:

DSA
 ECDSA
 RSA

Secure Hashing:

SHA-1
 SHA-2 (SHA-224, SHA-256, SHA-384, SHA-512)

Message Authentication:
 HMAC (SHA-1, SHA-2(224, 256, 384, 512)
 Random Number Generation:
 DRBG (Hash, HMAC and Counter)

Non FIPS Approved Algorithms

RNG (AES128/192/256)
 DES
 MD5

Ethernet

IEEE 802.2 Logical Link Control (LLC)
 IEEE 802.3 Ethernet
 IEEE 802.3ab 1000BASE-T
 IEEE 802.3ae 10 Gigabit Ethernet
 IEEE 802.3af Power over Ethernet (PoE)

IEEE 802.3at Power over Ethernet up to 30W (PoE+)
 IEEE 802.3az Energy Efficient Ethernet (EEE)
 IEEE 802.3bt Power over Ethernet up to 90W (PoE++)
 IEEE 802.3bz 2.5GBASE-T and 5GBASE-T ("multi-gigabit")
 IEEE 802.3u 100BASE-X
 IEEE 802.3x Flow control - full-duplex operation
 IEEE 802.3z 1000BASE-X

IPv4 Features

RFC 768 User Datagram Protocol (UDP)
 RFC 791 Internet Protocol (IP)
 RFC 792 Internet Control Message Protocol (ICMP)
 RFC 793 Transmission Control Protocol (TCP)
 RFC 826 Address Resolution Protocol (ARP)
 RFC 894 Standard for the transmission of IP datagrams over Ethernet networks
 RFC 919 Broadcasting Internet datagrams
 RFC 922 Broadcasting Internet datagrams in the presence of subnets
 RFC 932 Subnetwork addressing scheme
 RFC 950 Internet standard subnetting procedure
 RFC 1042 Standard for the transmission of IP datagrams over IEEE 802 networks
 RFC 1071 Computing the Internet checksum
 RFC 1122 Internet host requirements
 RFC 1191 Path MTU discovery
 RFC 1518 An architecture for IP address allocation with CIDR
 RFC 1519 Classless Inter-Domain Routing (CIDR)
 RFC 1812 Requirements for IPv4 routers
 RFC 1918 IP addressing
 RFC 2581 TCP congestion control

IPv6 Features

RFC 1981 Path MTU discovery for IPv6
 RFC 2460 IPv6 specification
 RFC 2464 Transmission of IPv6 packets over Ethernet networks
 RFC 2711 IPv6 router alert option
 RFC 3484 Default address selection for IPv6
 RFC 3587 IPv6 global unicast address format
 RFC 3596 DNS extensions to support IPv6
 RFC 4007 IPv6 scoped address architecture
 RFC 4193 Unique local IPv6 unicast addresses
 RFC 4213 Transition mechanisms for IPv6 hosts and routers
 RFC 4291 IPv6 addressing architecture
 RFC 4443 Internet Control Message Protocol (ICMPv6)
 RFC 4861 Neighbor discovery for IPv6
 RFC 4862 IPv6 Stateless Address Auto-Configuration (SLAAC)
 RFC 5014 IPv6 socket API for source address selection
 RFC 5095 Deprecation of type 0 routing headers in IPv6

Management

AT Enterprise MIB including AMF Plus MIB and SNMP traps
 Optical DDM MIB
 SNMPv1, v2c and v3
 ANSI/TIA-1057 LLDP-Media Endpoint Detection
 IEEE 802.1AB Link Layer Discovery Protocol (LLDP)
 RFC 1155 Structure and identification of management information for TCP/IP-based Internets
 RFC 1157 Simple Network Management Protocol (SNMP)
 RFC 1212 Concise MIB definitions
 RFC 1213 MIB for network management of TCP/IP-based Internets: MIB-II
 RFC 1215 Convention for defining traps for use with the SNMP
 RFC 1227 SNMP MUX protocol and MIB
 RFC 1239 Standard MIB
 RFC 1724 RIPv2 MIB extension
 RFC 2578 Structure of Management Information v2 (SMIv2)
 RFC 2579 Textual conventions for SMIv2
 RFC 2580 Conformance statements for SMIv2

RFC 2674 Definitions of managed objects for bridges with traffic classes, multicast filtering and VLAN extensions
 RFC 2741 Agent extensibility (AgentX) protocol
 RFC 2819 RMON MIB (groups 1,2,3 and 9)
 RFC 2863 Interfaces group MIB
 RFC 3176 sFlow: a method for monitoring traffic in switched and routed networks
 RFC 3411 An architecture for describing SNMP management frameworks
 RFC 3412 Message processing and dispatching for the SNMP
 RFC 3413 SNMP applications
 RFC 3414 User-based Security Model (USM) for SNMPv3
 RFC 3415 View-based Access Control Model (VACM) for SNMP
 RFC 3416 Version 2 of the protocol operations for the SNMP
 RFC 3417 Transport mappings for the SNMP
 RFC 3418 MIB for SNMP
 RFC 3621 Power over Ethernet (PoE) MIB
 RFC 3635 Definitions of managed objects for the Ethernet-like interface types
 RFC 3636 IEEE 802.3 MAU MIB
 RFC 4022 MIB for the Transmission Control Protocol (TCP)
 RFC 4113 MIB for the User Datagram Protocol (UDP)
 RFC 4188 Definitions of managed objects for bridges
 RFC 4292 IP forwarding table MIB
 RFC 4293 MIB for the Internet Protocol (IP)
 RFC 4318 Definitions of managed objects for bridges with RSTP
 RFC 4560 Definitions of managed objects for remote ping, traceroute and lookup operations
 RFC 5424 Syslog protocol

Multicast support

IGMP query solicitation
 IGMP snooping (IGMPv1, v2 and v3)
 IGMP snooping fast-leave
 MLD snooping (MLDv1 and v2)
 RFC 2715 Interoperability rules for multicast routing protocols
 RFC 3306 Unicast-prefix-based IPv6 multicast addresses
 RFC 4541 IGMP and MLD snooping switches

Quality of Service (QoS)

IEEE 802.1p Priority tagging
 IEEE 802.1Qaz Enhanced Transmission Selection (ETS)
 RFC 2211 Specification of the controlled-load network element service
 RFC 2474 DiffServ precedence for eight queues/port
 RFC 2475 DiffServ architecture
 RFC 2597 DiffServ Assured Forwarding (AF)
 RFC 2697 A single-rate three-color marker
 RFC 2698 A two-rate three-color marker
 RFC 3246 DiffServ Expedited Forwarding (EF)

Resiliency Features

ITU-T G.8032 Ethernet Ring Protection Switching (ERPS)
 IEEE 802.1ag Connectivity Fault Management (CFM), Continuity Check Protocol (CCP)
 IEEE 802.1AX Link aggregation (static and LACP)
 IEEE 802.1D MAC bridges
 IEEE 802.1s Multiple Spanning Tree Protocol (MSTP)
 IEEE 802.1w Rapid Spanning Tree Protocol (RSTP)
 IEEE 802.3adStatic and dynamic link aggregation

Routing Information Protocol (RIP)

RFC 1058 Routing Information Protocol (RIP)
 RFC 2082 RIP-2 MD5 authentication
 RFC 2453 RIPv2

Security Features

SSH remote login
 SSLv2 and SSLv3
 IEEE 802.1X Authentication protocols (TLS, TTLS, PEAP and MD5)
 IEEE 802.1X Multi-supplicant authentication
 IEEE 802.1X Port-based network access control
 RFC 2560 X.509 Online Certificate Status Protocol (OCSP)
 RFC 2818 HTTP over TLS ("HTTPS")
 RFC 2865 RADIUS authentication
 RFC 2866 RADIUS accounting
 RFC 2868 RADIUS attributes for tunnel protocol support
 RFC 2986 PKCS #10: certification request syntax specification v1.7
 RFC 3546 Transport Layer Security (TLS) extensions
 RFC 3579 RADIUS support for Extensible Authentication Protocol (EAP)
 RFC 3580 IEEE 802.1x RADIUS usage guidelines
 RFC 3748 PPP Extensible Authentication Protocol (EAP)
 RFC 4251 Secure Shell (SSHv2) protocol architecture
 RFC 4252 Secure Shell (SSHv2) authentication protocol
 RFC 4253 Secure Shell (SSHv2) transport layer protocol
 RFC 4254 Secure Shell (SSHv2) connection protocol
 RFC 5176 RADIUS CoA (Change of Authorization)
 RFC 5280 X.509 certificate and Certificate Revocation List (CRL) profile
 RFC 5425 Transport Layer Security (TLS) transport mapping for Syslog
 RFC 5656 Elliptic curve algorithm integration for SSH
 RFC 6125 Domain-based application service identity within PKI using X.509 certificates with TLS
 RFC 6614 Transport Layer Security (TLS) encryption for RADIUS
 RFC 6668 SHA-2 data integrity verification for SSH
 RFC 8446 Transport Layer Security (TLS) v1.3
 RFC 8894 Simple Certificate Enrollment Protocol (SCEP)

Services

RFC 854 Telnet protocol specification
 RFC 855 Telnet option specifications
 RFC 857 Telnet echo option
 RFC 858 Telnet suppress go ahead option
 RFC 1091 Telnet terminal-type option
 RFC 1350 Trivial File Transfer Protocol (TFTP)
 RFC 1985 SMTP service extension
 RFC 2049 MIME
 RFC 2131 DHCPv4 client
 RFC 2616 Hypertext Transfer Protocol - HTTP/1.1
 RFC 2821 Simple Mail Transfer Protocol (SMTP)
 RFC 2822 Internet message format
 RFC 3046 DHCP relay agent information option (DHCP option 82)
 RFC 3315 DHCPv6 client
 RFC 3396 Encoding long options in DHCPv4
 RFC 3646 DNS configuration options for DHCPv6
 RFC 3993 Subscriber-ID suboption for DHCP relay agent option
 RFC 4330 Simple Network Time Protocol (SNTP) version 4
 RFC 4954 SMTP service extension for authentication
 RFC 5905 Network Time Protocol (NTP) version 4

VLAN support

IEEE 802.1ad Provider bridges (VLAN stacking, Q-in-Q)
 IEEE 802.1Q Virtual LAN (VLAN) bridges
 IEEE 802.1v VLAN classification by protocol and port
 IEEE 802.3ac VLAN tagging

Feature Licenses

	Description	Includes
AT-FL-x240-APP	VLAN Q-in-Q and PTP license	<ul style="list-style-type: none"> ■ VLAN Q-in-Q ■ PTP Transparent Mode ■ VLAN translation
AT-FL-x240-OF13-1YR	OpenFlow license	<ul style="list-style-type: none"> ■ OpenFlow v1.3 for 1 year
AT-FL-x240-OF13-5YR	OpenFlow license	<ul style="list-style-type: none"> ■ OpenFlow v1.3 for 5 years

ORDERING INFORMATION

AT-x240-10GTXm	8-port 10M/100M/1/2.5/5G L3 stackable switch with 2 SFP+ ports, and a single fixed PSU
AT-x240-10GHXm	8-port 10M/100M/1/2.5/5G PoE++ L3 stackable switch with 2 SFP+ ports, and a single fixed PSU
AT-x240-26GTXm¹	24-port 10M/100M/1/2.5/5G L3 stackable switch with 2 SFP+ ports, and a single fixed PSU
AT-x240-26GHXm	24-port 10M/100M/1/2.5/5G PoE++ L3 stackable switch with 2 SFP+ ports, and a single fixed PSU
AT-x240-52GTXm¹	48-port 10M/100M/1/2.5/5G L3 stackable switch with 4 SFP+ ports, and a single fixed PSU
AT-x240-52GHXm¹	48-port 10M/100M/1/2.5/5G PoE++ L3 stackable switch with 4SFP+ ports, and a single fixed PSU
AT-RKMT-J13	Rack mount kit for x240-18GTXm/18GHXm
AT-RKMT-J14	Rack mount kit for x240-10GTXm/10GHXm
AT-RKMT-J15	Rack mount tray for x240-10GTXm/10GHXm
AT-BRKT-J24	Wall mount bracket
AT-STND-J03	Stand-kit for x240-10GTXm/10GHXm/18GTXm/18

¹ Models available in the future

Accessories

10GbE SFP+ Modules	
Any 10G SFP+ module or cable can be used for stacking with the front panel 10G ports	
AT-SP10SR	10GSR 850 nm short-haul, 300 m with MMF
AT-SP10SR/I	10GSR 850 nm short-haul, 300 m with MMF industrial temperature
AT-SP10LRa/I	10GLR 1310 nm medium-haul, 10 km with SMF industrial temperature, TAA ²
AT-SP10ZR80/I	10GER 1550 nm long-haul, 80 km with SMF industrial temperature
AT-SP10TM	1G/10G, 100 m copper, TAA ²

AT-SP10BD10/I-12	10 GbE Bi-Di (1270 nm Tx, 1330 nm Rx) fiber up to 10 km industrial temperature, TAA ²
AT-SP10BD10/I-13	10 GbE Bi-Di (1330 nm Tx, 1270 nm Rx) fiber up to 10 km industrial temperature, TAA ²
AT-SP10BD20-12	10 GbE Bi-Di (1270 nm Tx, 1330 nm Rx) fiber up to 20 km, TAA ²
AT-SP10BD20-13	10 GbE Bi-Di (1330 nm Tx, 1270 nm Rx) fiber up to 20 km, TAA ²
AT-SP10BD40/I-12	10 GbE Bi-Di (1270 nm Tx, 1330 nm Rx) fiber up to 40 km industrial temperature, TAA ²
AT-SP10BD40/I-13	10 GbE Bi-Di (1330 nm Tx, 1270 nm Rx) fiber up to 40 km industrial temperature, TAA ²

² Trade Act Agreement compliant

10GbE SFP+ Modules	
AT-SP10BD80/I-14	10 GbE Bi-Di (1490 nm Tx, 1550 nm Rx) fiber up to 80 km industrial temperature, TAA ²
AT-SP10BD80/I-15	10 GbE Bi-Di (1550nm Tx, 1490 nm Rx) fiber up to 80 km industrial temperature, TAA ²
10GbE SFP+ Cables	
AT-SP10TW1	1 meter SFP+ direct attach cable
AT-SP10TW3	3 meter SFP+ direct attach cable
1000Mbps SFP Modules	
AT-SPTXc	100 m, 10/100/1000T SFP, RJ-45
AT-SPSX	1000SX GbE multi-mode 850 nm fiber up to 550 m
AT-SPEX	1000X GbE multi-mode 1310 nm fiber up to 2 km
AT-SPSX/I	1000SX GbE multi-mode 850 nm fiber up to 550 m industrial temperature

² Trade Act Agreement compliant

1000Mbps SFP Modules	
AT-SPLX10a	1000LX SFP, LC, SMF, 1310nm (10km), TAA ²
AT-SPLX10a/I	1000LX GbE single-mode 1310 nm fiber up to 10 km industrial temperature
AT-SPLX40	1000LX GbE single-mode 1310 nm fiber up to 40 km
AT-SPBD10-13	1000LX GbE Bi-Di (1310 nm Tx, 1490 nm Rx) fiber up to 10 km
AT-SPBD10-14	1000LX GbE Bi-Di (1490 nm Tx, 1310 nm Rx) fiber up to 10 km
AT-SPBD20-13/I	1000BX GbE Bi-Di (1310 nm Tx, 1490 nm Rx) fiber up to 20 km industrial temperature
AT-SPBD20-14/I	1000BX GbE Bi-Di (1490 nm Tx, 1310 nm Rx) fiber up to 20 km industrial temperature
AT-SPBD40-13/I	1000LX GbE single-mode Bi-Di (1310 nm Tx, 1490 nm Rx) fiber up to 40 km, industrial temperature
AT-SPBD40-14/I	1000LX GbE single-mode Bi-Di (1490 nm Tx, 1310 nm Rx) fiber up to 40 km, industrial temperature